

JAWAPAN

BAB 1: ASAS NOMBOR

1.1

A

1. sama dengan
equals

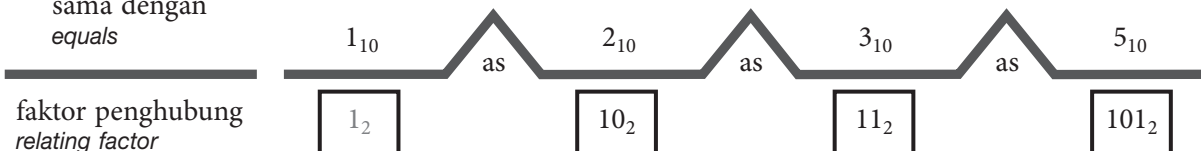

faktor penghubung
relating factor

2. sama dengan
equals

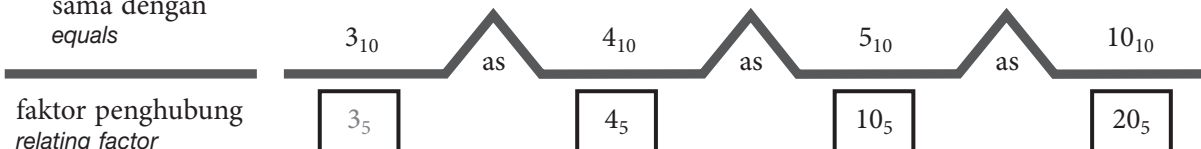

faktor penghubung
relating factor

3. sama dengan
equals

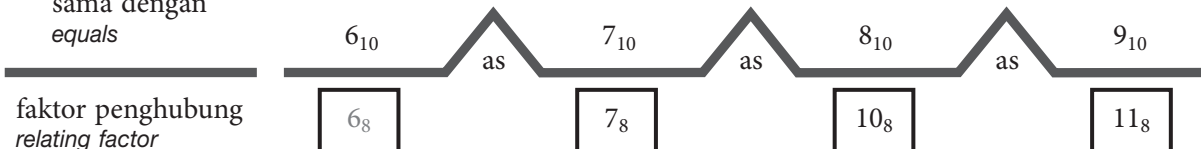

faktor penghubung
relating factor

B

1.

2^4	2^3	2^2	2^1	2^0
1	0	0	<u>1</u>	0

$$1 \times 2^1 = 1 \times 2$$

$$= 2$$

2.

2^4	2^3	2^2	2^1	2^0
<u>1</u>	1	0	0	1

$$1 \times 2^4 = 1 \times 16$$

$$= 16$$

3.

2^5	2^4	2^3	2^2	2^1	2^0
1	0	<u>1</u>	0	1	0

$$1 \times 2^3 = 1 \times 8$$

$$= 8$$

4.

2^5	2^4	2^3	2^2	2^1	2^0
1	<u>1</u>	0	0	1	0

$$1 \times 2^4 = 1 \times 16$$

$$= 16$$

5.

2^5	2^4	2^3	2^2	2^1	2^0
<u>1</u>	0	1	1	1	1

$$1 \times 2^5 = 1 \times 32$$

$$= 32$$

C

1.

8^3	8^2	8^1	8^0
2	3	4	<u>5</u>

$$5 \times 8^0 = 5 \times 1$$

$$= 5$$

2.

8^1	8^0
<u>7</u>	6

$$7 \times 8^1 = 7 \times 8$$

$$= 56$$

3.

8^2	8^1	8^0
<u>5</u>	7	1

$$5 \times 8^2 = 5 \times 64$$

$$= 320$$

4.

8^3	8^2	8^1	8^0
<u>1</u>	4	7	0

$$1 \times 8^3 = 1 \times 512$$

$$= 512$$

5.

8^5	8^4	8^3	8^2	8^1	8^0
7	<u>1</u>	5	6	0	1

$$1 \times 8^4 = 1 \times 4\,096$$

$$= 4\,096$$

D

1.

5^3	5^2	5^1	5^0
3	1	<u>4</u>	0

 $4 \times 5^1 = 4 \times 5$
 $= 20$

2.

5^1	5^0
<u>3</u>	4

 $3 \times 5^1 = 3 \times 5$
 $= 15$

3.

5^3	5^2	5^1	5^0
2	<u>1</u>	4	2

 $1 \times 5^2 = 1 \times 25$
 $= 25$

4.

5^4	5^3	5^2	5^1	5^0
<u>2</u>	0	1	4	3

 $2 \times 5^4 = 2 \times 625$
 $= 1\ 250$

5.

5^4	5^3	5^2	5^1	5^0
4	<u>3</u>	6	2	1

 $3 \times 5^3 = 3 \times 125$
 $= 375$

E

1.

2^4	2^3	2^2	2^1	2^0
1	0	0	0	0

 $1 \times 2^4 = 1 \times 16$
 $= 16$

G

Cerakinan <i>Expanded notation</i>	Nombor dalam asas dua <i>Number in base two</i>
1. $2^3 + 2^2 + 1 = \underline{1} \times 2^3 + \underline{1} \times 2^2 + \underline{0} \times 2^1 + \underline{1} \times 2^0$	1101_2
2. $2^4 + 2^2 + 2 = \underline{1} \times 2^4 + \underline{0} \times 2^3 + \underline{1} \times 2^2 + \underline{1} \times 2^1 + \underline{0} \times 2^0$	10110_2
3. $2^6 + 2^4 + 2^2 + 2 = \underline{1} \times 2^6 + \underline{0} \times 2^5 + \underline{1} \times 2^4 + \underline{0} \times 2^3 + \underline{1} \times 2^2 + \underline{1} \times 2^1 + \underline{0} \times 2^0$	1010110_2
4. $2(2^4 + 2) = 2^5 + 2^2 = \underline{1} \times 2^5 + \underline{0} \times 2^4 + \underline{0} \times 2^3 + \underline{1} \times 2^2 + \underline{0} \times 2^1 + \underline{0} \times 2^0$	100100_2

2.

8^2	8^1	8^0
6	1	4

 $1 \times 8^1 = 1 \times 8$
 $= 8$

3.

5^3	5^2	5^1	5^0
4	1	0	2

 $1 \times 5^2 = 1 \times 25$
 $= 25$

F

1. $1101_2 = 1 \times 2^3 + 1 \times 2^2 + 0 \times 2^1 + 1 \times 2^0$

2^3	2^2	2^1	2^0
1	1	0	1

2. $4567_8 = 4 \times 8^3 + 5 \times 8^2 + 6 \times 8^1 + 7 \times 8^0$

8^3	8^2	8^1	8^0
4	5	6	7

3. $2310_5 = 2 \times 5^3 + 3 \times 5^2 + 1 \times 5^1 + 0 \times 5^0$

5^3	5^2	5^1	5^0
2	3	1	0

4. $10111_2 = 1 \times 2^4 + 0 \times 2^3 + 1 \times 2^2 + 1 \times 2^1 + 1 \times 2^0$

5. $25370_8 = 2 \times 8^4 + 5 \times 8^3 + 3 \times 8^2 + 7 \times 8^1 + 0 \times 8^0$

6. $32041_5 = 3 \times 5^4 + 2 \times 5^3 + 0 \times 5^2 + 4 \times 5^1 + 1 \times 5^0$

H

Cerakinan <i>Expanded notation</i>	Nombor dalam asas lapan <i>Number in base eight</i>
1. $8^3 + 7 = \underline{1} \times 8^3 + \underline{0} \times 8^2 + \underline{0} \times 8^1 + \underline{7} \times 8^0$	1007 ₈
2. $4 \times 8^2 + 3 \times 8 + 2 = \underline{4} \times 8^2 + \underline{3} \times 8^1 + \underline{2} \times 8^0$	432 ₈
3. $2 \times 8^4 + 5 \times 8^2 + 4 = \underline{2} \times 8^4 + \underline{0} \times 8^3 + \underline{5} \times 8^2 + \underline{0} \times 8^1 + \underline{4} \times 8^0$	20504 ₈
4. $8(8^3 + 4 \times 8 + 1) = 8^4 + 4 \times 8^2 + 1 \times 8^1 = \underline{1} \times 8^4 + \underline{0} \times 8^3 + \underline{4} \times 8^2 + \underline{1} \times 8^1 + \underline{0} \times 8^0$	10410 ₈

I

Cerakinan <i>Expanded notation</i>	Nombor dalam asas lima <i>Number in base five</i>
1. $5^4 + 5 + 2 = \underline{1} \times 5^4 + \underline{0} \times 5^3 + \underline{0} \times 5^2 + \underline{1} \times 5^1 + \underline{2} \times 5^0$	10012 ₅
2. $4 \times 5^4 + 3 \times 5^2 + 1 = \underline{4} \times 5^4 + \underline{0} \times 5^3 + \underline{3} \times 5^2 + \underline{0} \times 5^1 + \underline{1} \times 5^0$	40301 ₅
3. $2 \times 5^4 + 5^2 + 2 \times 5 + 3 = \underline{2} \times 5^4 + \underline{0} \times 5^3 + \underline{1} \times 5^2 + \underline{2} \times 5^1 + \underline{3} \times 5^0$	20123 ₅
4. $5(5^3 + 2) = 5^4 + 5 \times 2 = \underline{1} \times 5^4 + \underline{0} \times 5^3 + \underline{0} \times 5^2 + \underline{2} \times 5^1 + \underline{0} \times 5^0$	10020 ₅

J

- $1011_2 = 1 \times 2^3 + 0 \times 2^2 + 1 \times 2^1 + 1 \times 2^0$
 $= 8 + 0 + 2 + 1$
 $= 11_{10}$
- $101011_2 = 1 \times 2^5 + 0 \times 2^4 + 1 \times 2^3 + 0 \times 2^2 + 1 \times 2^1 + 1 \times 2^0$
 $= 32 + 0 + 8 + 0 + 2 + 1$
 $= 43_{10}$
- $65_8 = 6 \times 8^1 + 5 \times 8^0$
 $= 48 + 5$
 $= 53_{10}$
- $2147_8 = 2 \times 8^3 + 1 \times 8^2 + 4 \times 8^1 + 7 \times 8^0$
 $= 1024 + 64 + 32 + 7$
 $= 1127_{10}$
- $413_5 = 4 \times 5^2 + 1 \times 5^1 + 3 \times 5^0$
 $= 100 + 5 + 3$
 $= 108_{10}$
- $5342_5 = 5 \times 5^3 + 3 \times 5^2 + 4 \times 5^1 + 2 \times 5^0$
 $= 625 + 75 + 20 + 2$
 $= 722_{10}$

K

- $1 \times 2^4 + m \times 2^3 + 1 \times 2^0 = 25$
 $16 + 8m + 1 = 25$
 $17 + 8m = 25$
 $8m = 8$
 $m = 1$
- $3 \times 8^2 + 5 \times 8^1 + m \times 8^0 = 238$
 $192 + 40 + m = 238$
 $232 + m = 238$
 $m = 6$
- $m \times 5^2 + 1 \times 5^1 + 4 \times 5^0 = 59$
 $25m + 5 + 4 = 59$
 $25m + 9 = 59$
 $25m = 50$
 $m = 2$

L

1. (i)

2	38	Baki
2	190
2	91
2	41
2	20
2	10
	01

Maka, $38_{10} = 100110_2$

$$(ii) \begin{array}{r} 8 \overline{) 38} \quad \text{Baki} \\ 8 \overline{) 4} \quad \dots\dots 6 \uparrow \\ \quad 0 \quad \dots\dots 4 \end{array}$$

Maka, $38_{10} = 46_8$

$$(iii) \begin{array}{r} 5 \overline{) 38} \quad \text{Baki} \\ 5 \overline{) 7} \quad \dots\dots 3 \uparrow \\ 5 \overline{) 1} \quad \dots\dots 2 \\ \quad 0 \quad \dots\dots 1 \end{array}$$

Maka, $38_{10} = 123_5$

$$2. (i) \begin{array}{r} 2 \overline{) 462} \quad \text{Baki} \\ 2 \overline{) 231} \quad \dots\dots 0 \uparrow \\ 2 \overline{) 115} \quad \dots\dots 1 \\ 2 \overline{) 57} \quad \dots\dots 1 \\ 2 \overline{) 28} \quad \dots\dots 1 \\ 2 \overline{) 14} \quad \dots\dots 0 \\ 2 \overline{) 7} \quad \dots\dots 0 \\ 2 \overline{) 3} \quad \dots\dots 1 \\ 2 \overline{) 1} \quad \dots\dots 1 \\ \quad 0 \quad \dots\dots 1 \end{array}$$

Maka, $462_{10} = 111001110_2$

$$(ii) \begin{array}{r} 8 \overline{) 462} \quad \text{Baki} \\ 8 \overline{) 57} \quad \dots\dots 6 \uparrow \\ 8 \overline{) 7} \quad \dots\dots 1 \\ \quad 0 \quad \dots\dots 7 \end{array}$$

Maka, $462_{10} = 716_8$

$$(iii) \begin{array}{r} 5 \overline{) 462} \quad \text{Baki} \\ 5 \overline{) 92} \quad \dots\dots 2 \uparrow \\ 5 \overline{) 18} \quad \dots\dots 2 \\ 5 \overline{) 3} \quad \dots\dots 3 \\ \quad 0 \quad \dots\dots 3 \end{array}$$

Maka, $462_{10} = 3322_5$

M

1. $24_8 = 10100_2$

2			4_8		
4	2	1	4	2	1
0	1	0	1	0	0

2. $765_8 = 111110101_2$

7			6			5_8		
4	2	1	4	2	1	4	2	1
1	1	1	1	1	0	1	0	1

$$3. 412_5 = 4 \times 5^2 + 1 \times 5^1 + 2 \times 5^0 \\ = 100 + 5 + 2 \\ = 107_{10} \\ = 1101011_2$$

$$\begin{array}{r} 2 \overline{) 107} \quad \text{Baki} \\ 2 \overline{) 53} \quad \dots\dots 1 \uparrow \\ 2 \overline{) 26} \quad \dots\dots 1 \\ 2 \overline{) 13} \quad \dots\dots 0 \\ 2 \overline{) 6} \quad \dots\dots 1 \\ 2 \overline{) 3} \quad \dots\dots 0 \\ 2 \overline{) 1} \quad \dots\dots 1 \\ \quad 0 \quad \dots\dots 1 \end{array}$$

N

1. $110101_2 = 65_8$

4	2	1	4	2	1
1	1	0	1	0	1
6			5_8		

2. $100000111_2 = 407_8$

4	2	1	4	2	1	4	2	1
1	0	0	0	0	0	1	1	1
4			0			7_8		

$$3. 242_5 = 2 \times 5^2 + 4 \times 5^1 + 2 \times 5^0 \\ = 50 + 20 + 2 \\ = 72_{10} \\ = 110_8$$

$$\begin{array}{r} 8 \overline{) 72} \quad \text{Baki} \\ 8 \overline{) 9} \quad \dots\dots 0 \uparrow \\ 8 \overline{) 1} \quad \dots\dots 1 \\ \quad 0 \quad \dots\dots 1 \end{array}$$

O

$$1. 11010_2 = 1 \times 2^4 + 1 \times 2^3 + 0 \times 2^2 + 1 \times 2^1 + 0 \times 2^0 \\ = 16 + 8 + 0 + 2 + 0 \\ = 26_{10} \\ = 101_5$$

$$\begin{array}{r} 5 \overline{) 26} \quad \text{Baki} \\ 5 \overline{) 5} \quad \dots\dots 1 \uparrow \\ 5 \overline{) 1} \quad \dots\dots 0 \\ \quad 0 \quad \dots\dots 1 \end{array}$$

$$2. 152_8 = 1 \times 8^2 + 5 \times 8^1 + 2 \times 8^0 \\ = 64 + 40 + 2 \\ = 106_{10} \\ = 411_5$$

$$\begin{array}{r} 5 \overline{) 106} \quad \text{Baki} \\ 5 \overline{) 21} \quad \dots\dots 1 \uparrow \\ 5 \overline{) 4} \quad \dots\dots 1 \\ \quad 0 \quad \dots\dots 4 \end{array}$$

$$3. 643_8 = 6 \times 8^2 + 4 \times 8^1 + 3 \times 8^0 \\ = 384 + 32 + 3 \\ = 419_{10} \\ = 3134_5$$

$$\begin{array}{r} 5 \overline{) 419} \quad \text{Baki} \\ 5 \overline{) 83} \quad \dots\dots 4 \uparrow \\ 5 \overline{) 16} \quad \dots\dots 3 \\ 5 \overline{) 3} \quad \dots\dots 1 \\ \quad 0 \quad \dots\dots 3 \end{array}$$

P

$$\begin{array}{r} 1. \quad 1101 \\ + \quad 110 \\ \hline 10011_2 \end{array}$$

$$\begin{array}{r} 2. \quad 10101 \\ + \quad 101 \\ \hline 11010_2 \end{array}$$

$$\begin{array}{r} 3. \quad 10110 \\ + \quad 1101 \\ \hline 100011_2 \end{array}$$

$$\begin{array}{r} 4. \quad 1011 \\ - \quad 111 \\ \hline 100_2 \end{array}$$

$$\begin{array}{r} 5. \quad 10100 \\ - \quad 111 \\ \hline 1101_2 \end{array}$$

$$\begin{array}{r} 6. \quad 101110 \\ - \quad 11011 \\ \hline 10011_2 \end{array}$$

7. 1110_2

8. 100110_2

9. 110110_2

10. 1001111_2

11. 101_2

12. 1001_2

13. 11000_2

14. 10011_2

Praktis Formatif: Kertas 1

1. C
 $1101_2 = 1 \times 2^2$
 $= 1 \times 4$
 $= 4$

2. B
 $567_8 = 6 \times 8^1$
 $= 48$

3. B
 $32421_5 = 4 \times 5^2$
 $= 4 \times 25$
 $= 100$

4. C
 $2^5 + 2^2 + 1$
 $= 1 \times 2^5 + 0 \times 2^4 + 0 \times 2^3 + 1 \times 2^2 + 0 \times 2^1 + 1 \times 2^0$
 $= 100101_2$

5. C
 $2^p + 2^4 + 1 = 10010001_2$
 $2^p = 1 \times 2^7$
 $p = 7$

6. C
 $6 \times 8^4 + 3 \times 8^2 + 1$
 $= 6 \times 8^4 + 0 \times 8^3 + 3 \times 8^2 + 0 \times 8^1 + 1 \times 8^0$
 $= 60301_8$

7. C
 $1 \times 8^3 + 6 \times 8$
 $= 1 \times 8^3 + 0 \times 8^2 + 6 \times 8^1 + 0 \times 8^0$
 $= 1060_8$

8. A
 $5(5^4 + 3)$
 $= 5^5 + 3 \times 5^1$
 $= 1 \times 5^5 + 0 \times 5^4 + 0 \times 5^3 + 0 \times 5^2 + 3 \times 5^1 + 0 \times 5^0$
 $= 100030_5$

9. C
 $3(5^4 + 5)$
 $= 3 \times 5^4 + 3 \times 5^1$
 $= 3 \times 5^4 + 0 \times 5^3 + 0 \times 5^2 + 3 \times 5^1 + 0 \times 5^0$
 $= 30030_5$

10. D
 $P_5 = 5(5^4 + 5^2 + 5^1)$
 $= 5^5 + 5^3 + 5^2$
 $= 101100_5$
 Bilangan digit = 6

11. D
 $376_8 = 3 \times 8^2 + 7 \times 8^1 + 6 \times 8^0$
 $= 254_{10}$
 $= 2004_5$

5	254	Baki
5	504
5	100
5	20
	02

12. A

		1	1	0	1	0	0	1_2
4	2	1	4	2	1	4	2	1
1		5			1 ₈			

$1101001_2 = 151_8$

13. C

$$\begin{aligned}
 1330_5 &= 1 \times 5^3 + 3 \times 5^2 + 3 \times 5^1 + 0 \\
 &= 215_{10} \\
 &= 327_8 \\
 \therefore p &= 3
 \end{aligned}$$

$$\begin{array}{r}
 8 \overline{) 215} \quad \text{Baki} \\
 \underline{8 \quad 26} \quad \dots\dots 7 \uparrow \\
 8 \quad \underline{3} \quad \dots\dots 2 \\
 0 \quad \dots\dots 3
 \end{array}$$

14. D

	1	0	1	0	1	0	0	1 ₂
4	2	1	4	2	1	4	2	1
	2		5					1 ₈

$$k = 5$$

15. B

$$\begin{aligned}
 161_{10} &= 1m21_5 \\
 &= 1121_5 \\
 \therefore m &= 1
 \end{aligned}$$

$$\begin{array}{r}
 5 \overline{) 161} \quad \text{Baki} \\
 \underline{5 \quad 32} \quad \dots\dots 1 \uparrow \\
 5 \quad \underline{6} \quad \dots\dots 2 \\
 5 \quad \underline{1} \quad \dots\dots 1 \\
 0 \quad \dots\dots 1
 \end{array}$$

16. C

0	0	1	1	1	0	1	1	1 ₂
4	2	1	4	2	1	4	2	1
	1		6					7 ₈

$$p = 167$$

17. B

$$\begin{aligned}
 67_8 &= 6 \times 8^1 + 7 \times 8^0 \\
 &= 55_{10} \\
 53_{10} &< x_{10} < 55_{10} \\
 x_{10} &= 54_{10} \\
 &= 110110_2
 \end{aligned}$$

$$\begin{array}{r}
 2 \overline{) 54} \quad \text{Baki} \\
 \underline{2 \quad 27} \quad \dots\dots 0 \uparrow \\
 2 \quad \underline{13} \quad \dots\dots 1 \\
 2 \quad \underline{6} \quad \dots\dots 1 \\
 2 \quad \underline{3} \quad \dots\dots 0 \\
 2 \quad \underline{1} \quad \dots\dots 1 \\
 0 \quad \dots\dots 1
 \end{array}$$

18. D

$$\begin{aligned}
 370_8 &= 3 \times 8^2 + 7 \times 8^1 \\
 &= 248_{10} \\
 248_{10} &= q_{10} - 5_{10} \\
 q_{10} &= 248_{10} + 5_{10} \\
 &= 253_{10} \\
 \therefore q &= 253
 \end{aligned}$$

19. D

$$\begin{array}{r}
 1 \ 1 \ 0 \ 0 \ 1_2 \\
 + \quad 1 \ 0 \ 1_2 \\
 \hline
 1 \ 1 \ 1 \ 1 \ 0_2
 \end{array}$$

20. D

$$\begin{array}{r}
 1 \ 0 \ 1 \ 0 \ 0 \ 1 \ 1_2 \\
 - \quad 1 \ 0 \ 1 \ 0 \ 1_2 \\
 \hline
 1 \ 1 \ 1 \ 1 \ 1 \ 0_2
 \end{array}$$

21. D

$$\begin{array}{r}
 1 \ 0 \ 1 \ 0 \ 0_2 \\
 - \quad 1 \ 0 \ 1_2 \\
 \hline
 1 \ 1 \ 1 \ 1_2
 \end{array}$$

22. C

$$\begin{array}{r}
 1 \ 1 \ 0 \ 1 \ 0 \ 1_2 \\
 - \quad 1 \ 1 \ 1_2 \\
 \hline
 1 \ 0 \ 1 \ 1 \ 1 \ 0_2
 \end{array}$$

23. A

$$\begin{array}{r}
 1 \ 0 \ 1 \ 0 \ 1_2 \\
 - \quad 1 \ 0 \ 1 \ 1_2 \\
 \hline
 1 \ 0 \ 1 \ 0_2
 \end{array}$$

24. A

$$\begin{array}{r}
 1 \ 1 \ 0 \ 0 \ 1 \ 1 \ 0 \ 1_2 \\
 - \ 1 \ 0 \ 0 \ 1 \ 1 \ 1 \ 1 \ 0_2 \\
 \hline
 1 \ 1 \ 1 \ 1 \ 1 \ 1 \ 1_2
 \end{array}$$

25. B

$$\begin{aligned}
 x_2 + 10100_2 &= 11010001_2 \\
 x_2 &= 11010001_2 - 10100_2 \\
 &= 10111101_2 \\
 1 \ 1 \ 0 \ 1 \ 0 \ 0 \ 0 \ 1_2 \\
 - \quad 1 \ 0 \ 1 \ 0 \ 0_2 \\
 \hline
 1 \ 0 \ 1 \ 1 \ 1 \ 1 \ 0 \ 1_2
 \end{aligned}$$

FOKUS KBAT

$$3 \times 3 = 9$$

Asas 10	7 ₁₀	8 ₁₀	9 ₁₀
Asas 2	111 ₂	1000 ₂	1011 ₂
Asas 8	7 ₈	10 ₈	11 ₈
Asas 5	12 ₅	13 ₅	14 ₅

Maka, $x = 10$, $y = 8$ dan $z = 5$. (D)

JAWAPAN

BAB 2: GRAF FUNGSI II

2.1

A

1. $y = 3x + 4$

x	-1	0	3
y	1	4	13

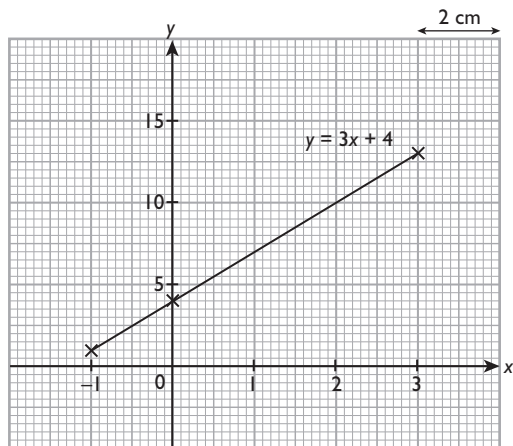

2. $y = 7 - x$

x	0	3	7
y	7	4	0

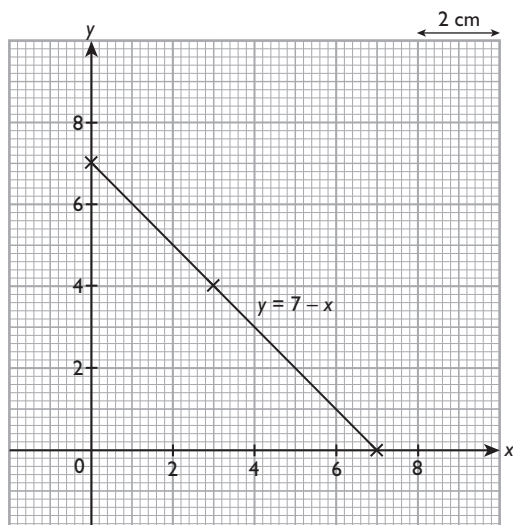

B

1. $y = 2x^2 - 4x - 10$

x	-2	-1	0	1	2	3	4
y	6	-4	-10	-12	-10	-4	6

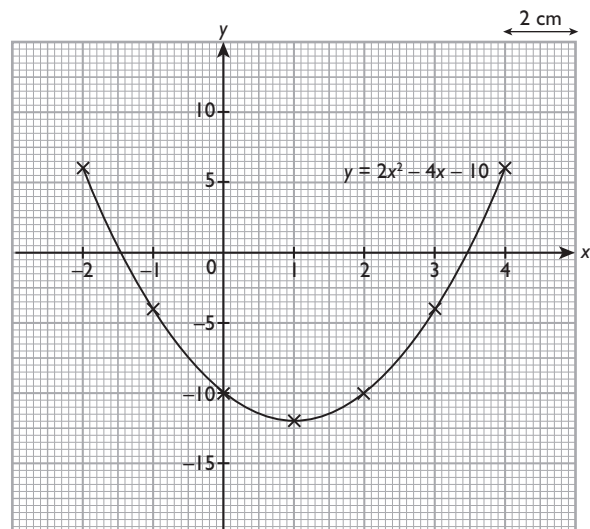

2. $y = -2x^2 - 3x + 8$

x	-3.5	-3	-2	-1	0	1	2
y	-6	-1	6	9	8	3	-6

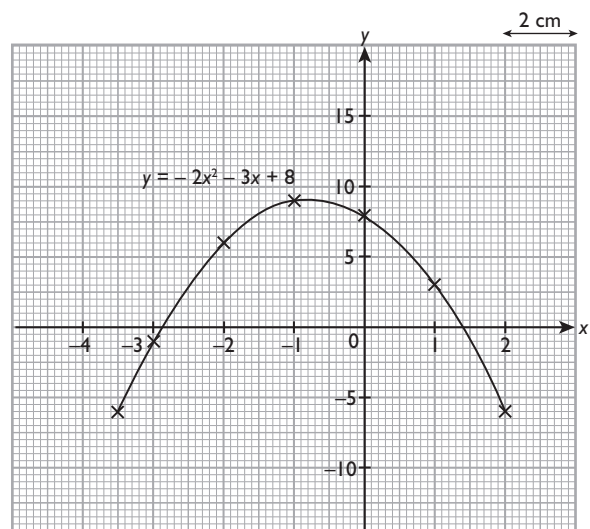

C

1. $y = x^3 + 7$

x	-3	-2	-1	0	1	2	3
y	-20	-1	6	7	8	15	34

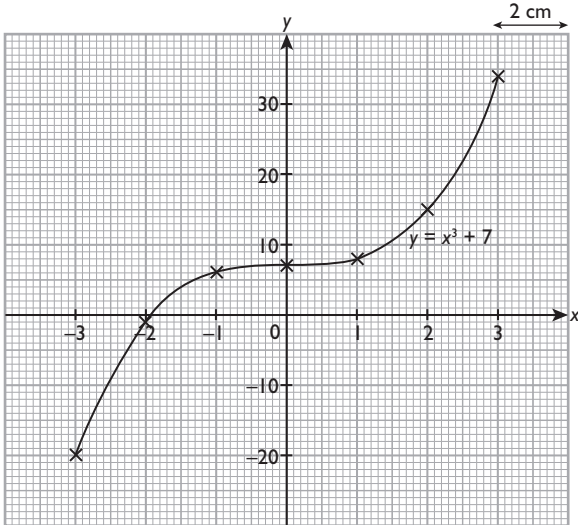

2. $y = 2 + 6x - x^3$

x	-3	-2	-1	0	1	2	3
y	11	-2	-3	2	7	6	-7

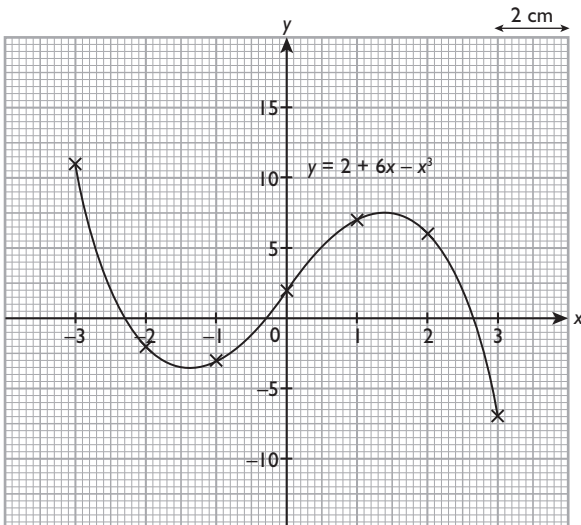

D

1. $y = -\frac{6}{x}$

x	-3	-2	-1.5	-1	1	1.5	2	3
y	2	3	4	6	-6	-4	-3	-2

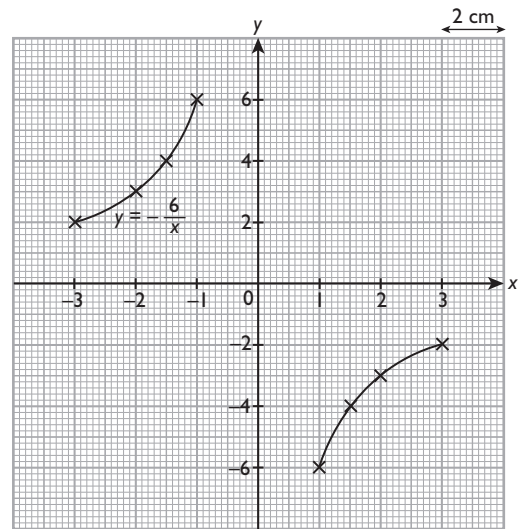

2. $y = -\frac{12}{x}$

x	-3	-2	-1.5	-1	1	1.5	2	3
y	4	6	8	12	-12	-8	-6	-4

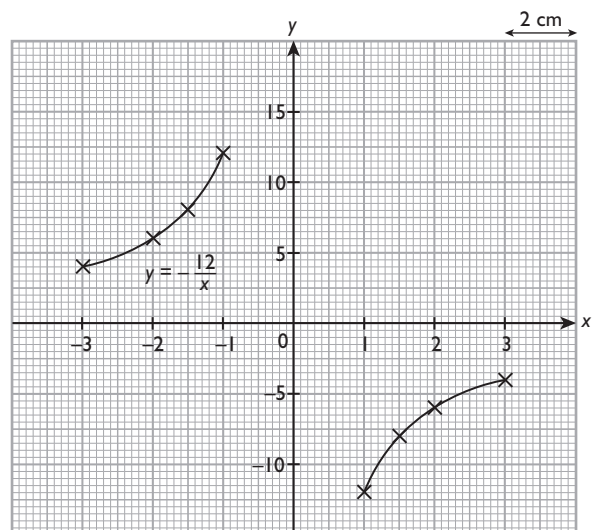

E

1. $y = 2x^2 - 7x + 3$

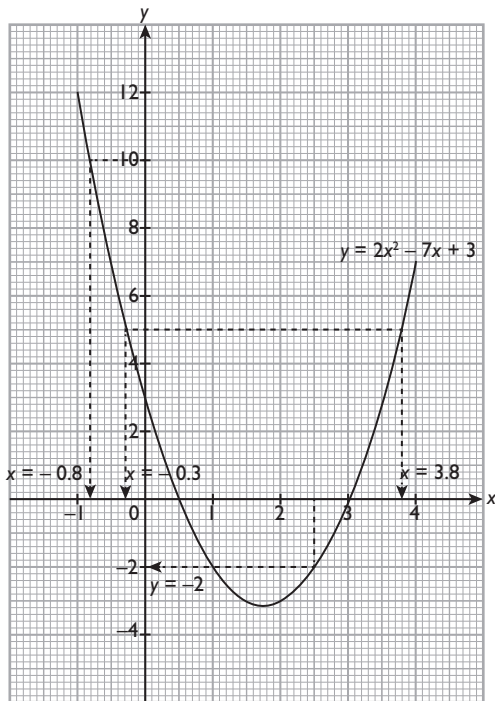

- (a) $y = -2$
- (b) $x = -0.3, 3.8$
- (c) $x = -0.8$

2. $y = x^3 - 11x + 5$

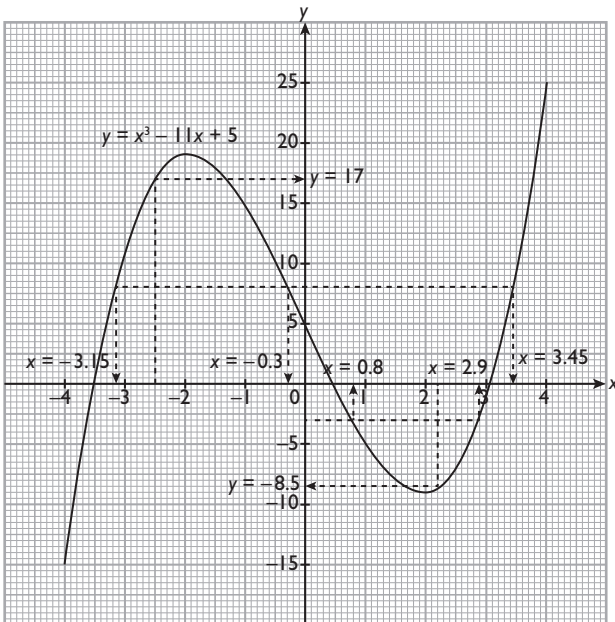

- (a) $y = 17$
- (b) $y = -8.5$
- (c) $x = -3.2, -0.3, 3.5$
- (d) $x = 0.8, 2.9$

E

1. $y = 2x - 4$

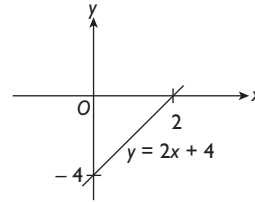

2. $y = 6 - 3x$

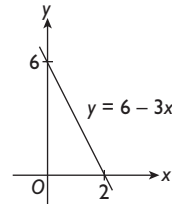

3. $4y = x - 8$

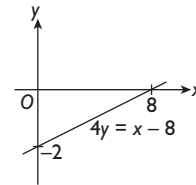

4. $y = x^2 + 3$

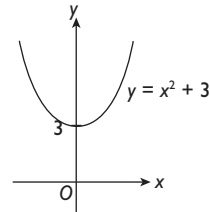

5. $y = 7 - x^2$

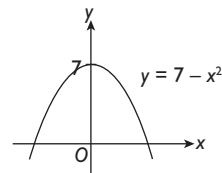

6. $y = (x - 4)(x + 2)$

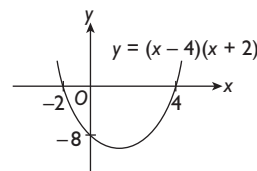

7. $y = x^3 + 5$

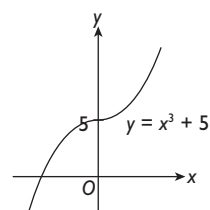

8. $y = x^3 - 4$

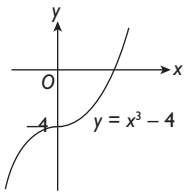

9. $y = 8 - x^3$

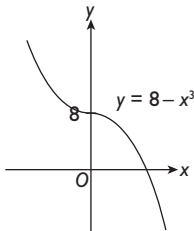

10. $y = \frac{2}{x}$

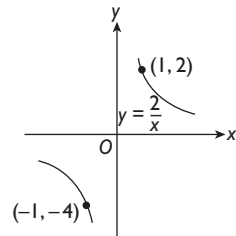

11. $y = -\frac{3}{x}$

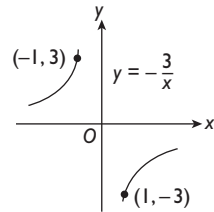

12. $y = -5x^{-1}$

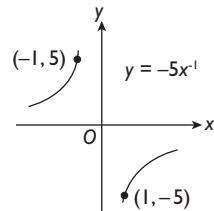

2.2

1. (a) $y = 2x^2 - 3x - 2$

x	-1	2
y	3	0

(b)

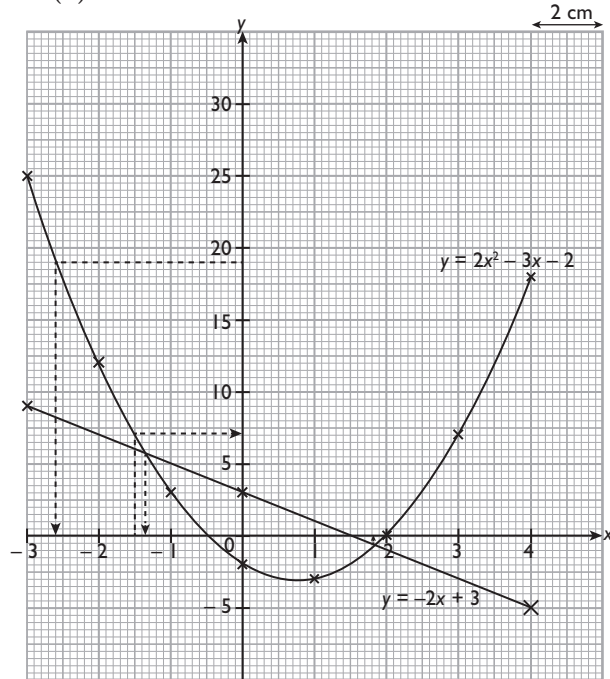

(c) (i) $y = 7.5$

(ii) $x = -2.6$

(d) $y = 2x^2 - 3x - 2 \dots \textcircled{1}$

$0 = 2x^2 - x - 5 \dots \textcircled{2}$

$\textcircled{1} - \textcircled{2}: y = -2x + 3$

Persamaan garis lurus: $y = -2x + 3$

$x = -1.35, 1.85$

2. (a) $y = x^3 - 3x - 10$

x	-1	3
y	-8	8

(b)

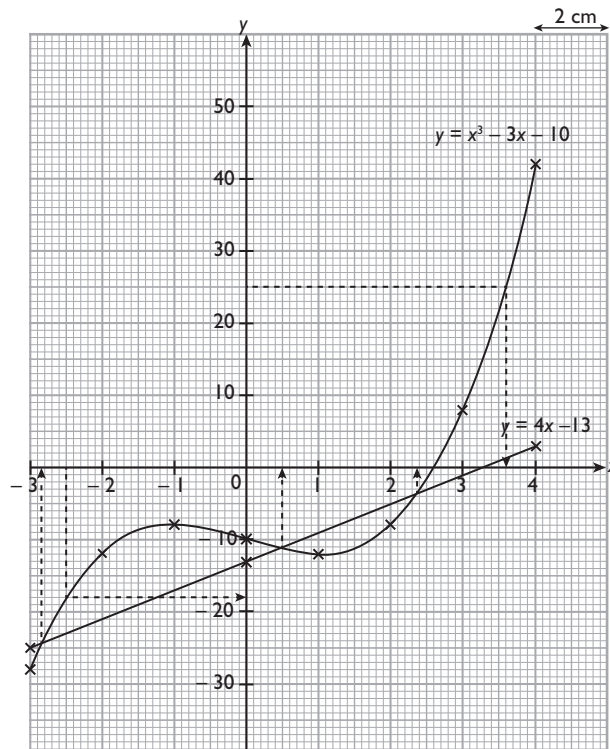

- (c) (i) $y = -18$
(ii) $x = 3.6$
- (d) $y = x^3 - 3x - 10 \dots \textcircled{1}$
 $0 = x^3 - 7x + 3 \dots \textcircled{2}$
 $\textcircled{1} - \textcircled{2}: y = 4x - 13$
Persamaan garis lurus: $y = 4x - 13$
 $x = -2.85, 0.5, 2.35$

3. (a) $y = -\frac{10}{x}$

x	-2.5	1
y	4	-10

(b)

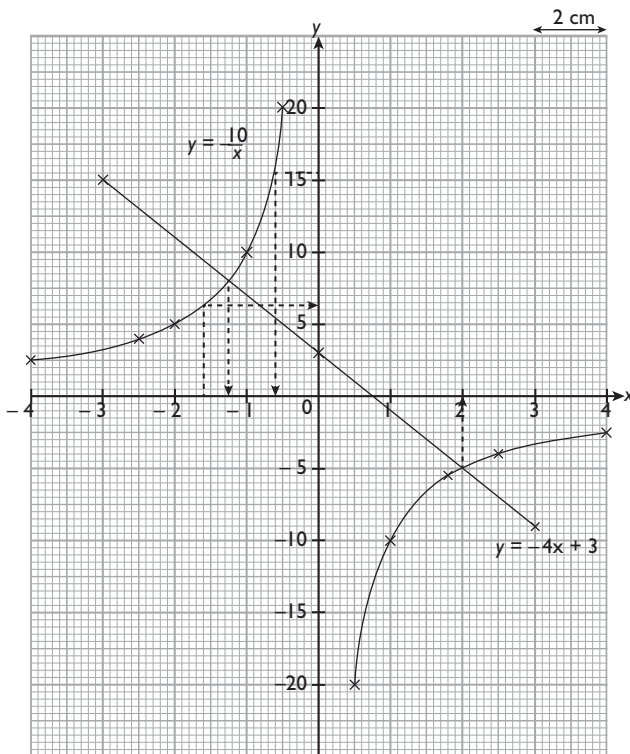

- (c) (i) $y = 6.25$
(ii) $x = -0.6$

(d) $y = -\frac{10}{x} \dots \textcircled{1}$
 $0 = 4x^2 - 3x - 10 \dots \textcircled{2}$
 $\textcircled{2} \div x: 0 = 4x - 3 - \frac{10}{x}$
 $0 = 4x - 3 + y$
 $y = -4x + 3$

Persamaan garis lurus: $y = -4x + 3$
 $x = -1.25, 2$

4. (a) $h = -3t^2 + 9t + 12$

t (s)	1	3
h (m)	18	12

(b)

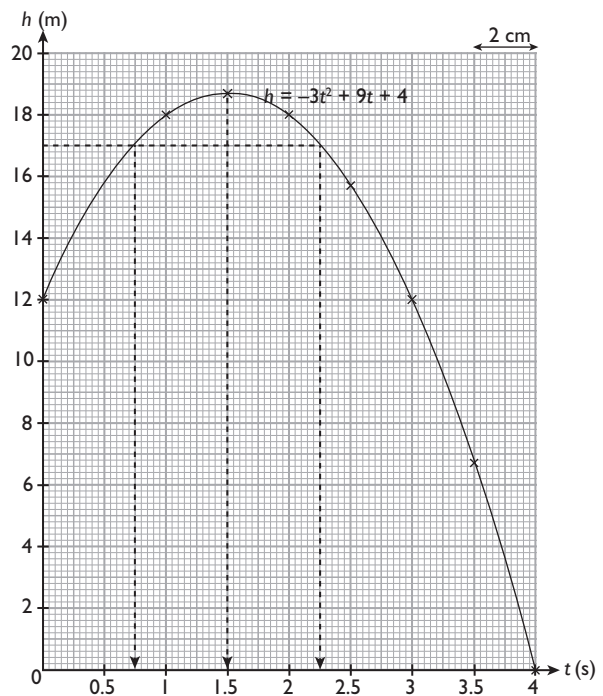

- (c) (i) 0.75 saat dan 2.25 saat
(ii) 1.5 saat
(iii) 4 saat

2.3

1. $y > \frac{1}{2}x, y \geq 5 - x, y \leq 3$

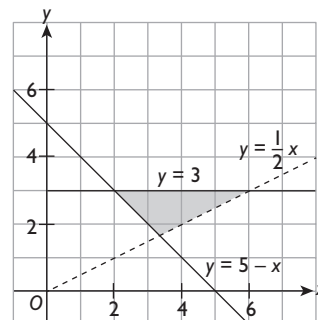

2. $y < 7 - x, 2y \geq x, x \geq 0$

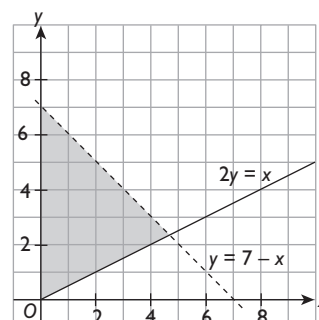

3. $y < x, y \leq -x + 7, y \geq 0$

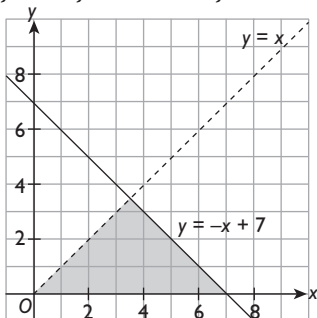

4. $y < -x, x \geq -5, y \geq x + 5$

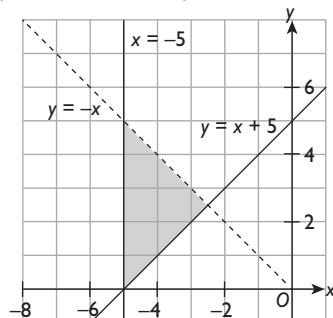

5. $y < 2x - 6, y \leq 1 - x, y \geq -4$

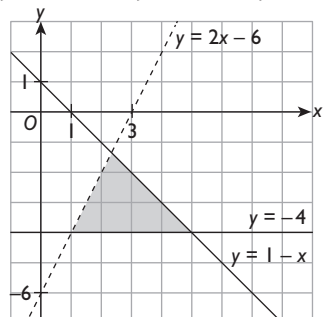

6. $y < x, y \geq 4 - x, x \leq 4$

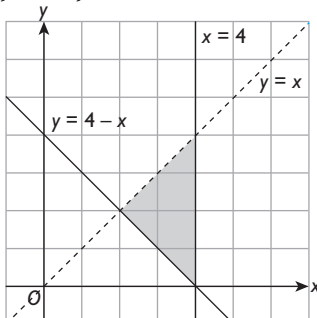

7. $y \geq -x + 6, y \leq 6, y > x$

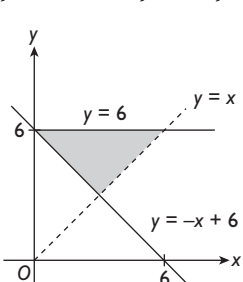

8. $y < -x - 5, y \geq x, x \geq -5$

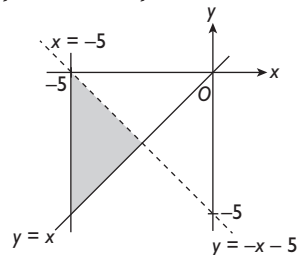

Praktis Formatif: Kertas 1

1. C

$y = x^2 - 4$

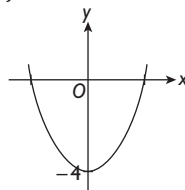

2. C

$y = 4x^3 + 4$
 $y = 0; 0 = 4x^3 + 4$
 $4x^3 = -4$
 $x^3 = -1$
 $x = -1$

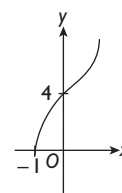

3. B

$y = 18 - 2x^2$
 $y = 0; 0 = 18 - 2x^2$
 $2x^2 = 18$
 $x^2 = 9$
 $x = \pm 3$

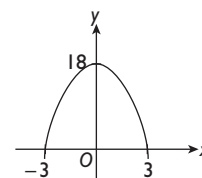

4. A

$y = -\frac{5}{x}$
 $x = -1; y = -\frac{5}{(-1)}$
 $= 5$

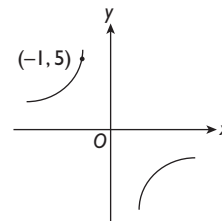

5. B

$y = -x^2 - 7x - 12$
 $y = 0; 0 = -x^2 - 7x - 12$
 $0 = (x + 4)(x + 3)$
 $x = -4, x = -3$

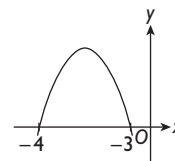

6. D

$y = 6x^{-1}$
 $y = \frac{6}{x}$
 $x = -1, y = \frac{6}{(-1)}$
 $= -6$

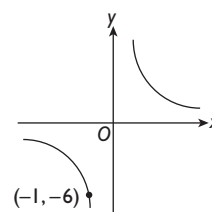

7. A

$$y = x^3 + 27$$

$$y = 0; 0 = x^3 + 27$$

$$x^3 = -27$$

$$x = -3$$

8. C

$$y = ax^n + c$$

$$a = 1, n = 3, c = 4$$

$$y = x^3 + 4$$

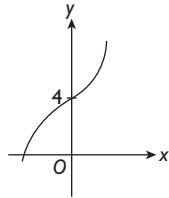

9. D

$$y = 4 + x - 3x^2$$

$$y = 0; 0 = 4 + x - 3x^2$$

$$0 = (x + 1)(3x - 4)$$

$$\therefore x = -1, x = \frac{4}{3}$$

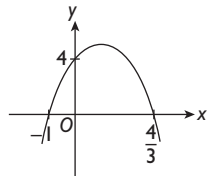

10. D

$$xy = -7$$

$$y = -\frac{7}{x}$$

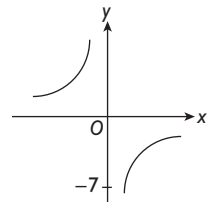

11. B

$$y = x^3 + 27$$

12. A

$$y = -x^2 + 4$$

$$y = 0; 0 = -x^2 + 4$$

$$x^2 = 4$$

$$x = \pm 2$$

Praktis Formatif: Kertas 2

1.

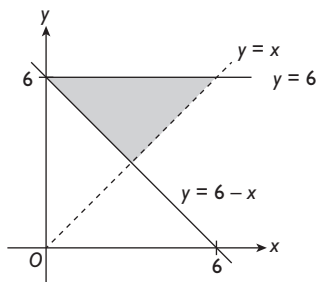

2.

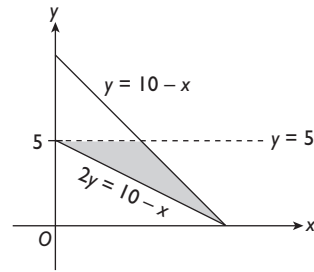

3.

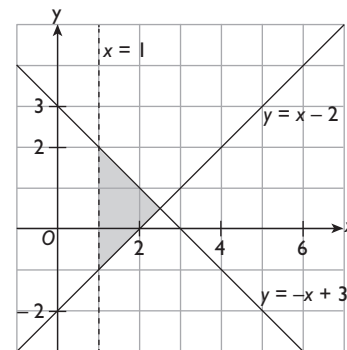

4.

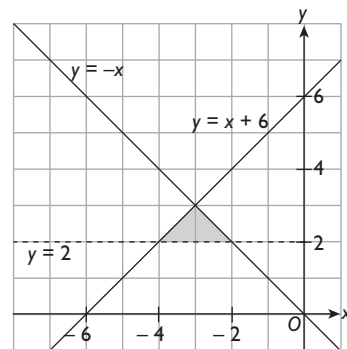

5.

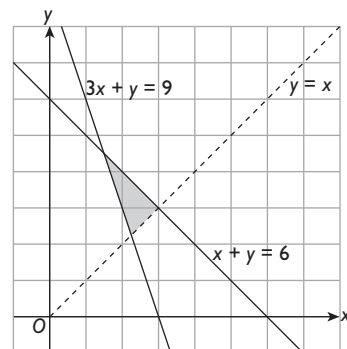

6.

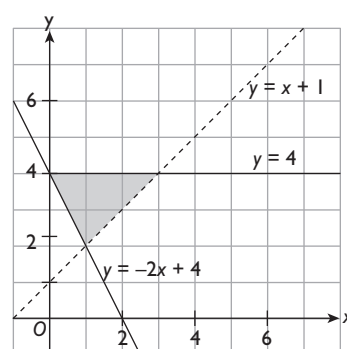

7. (a) $y = -2x^2 + 6x + 11$

x	-2	3
y	-9	11

(b)

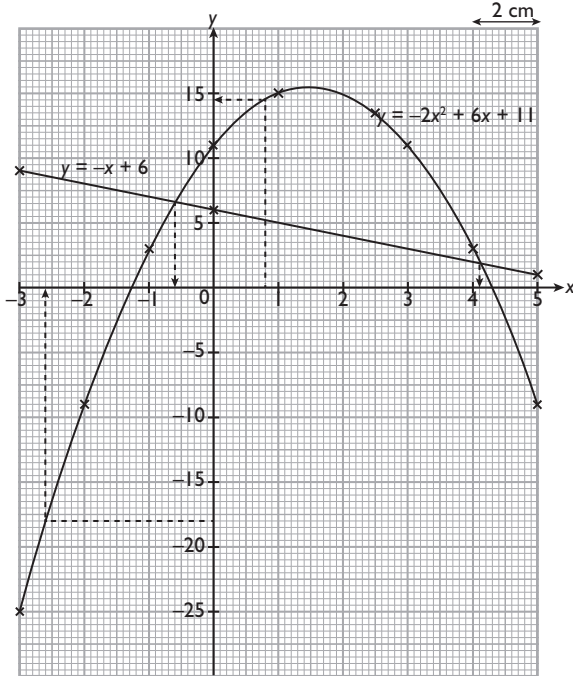

- (c) (i) 14.5
(ii) -2.6

(d) $y = -2x^2 + 6x + 11 \dots \textcircled{1}$
 $0 = -2x^2 + 7x + 5 \dots \textcircled{2}$
 $\textcircled{1} - \textcircled{2}: y = -x + 6$
 Persamaan garis lurus: $y = -x + 6$
 $x = -0.6, 4.1$

8. (a) $y = \frac{12}{x}$

x	0.8	5
y	15	2.4

(b)

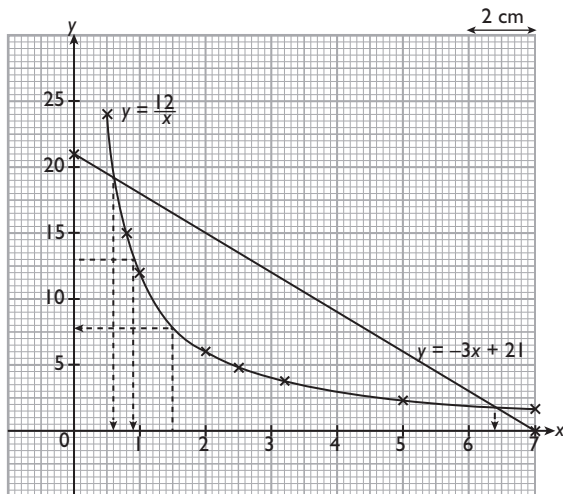

- (c) (i) 7.75
(ii) 0.9

(d) $y = \frac{12}{x} \dots \textcircled{1}$
 $12 = -3x^2 + 21x \dots \textcircled{2}$
 $\textcircled{2} \div x: \frac{12}{x} = -3x + 21 \dots \textcircled{3}$

Gantikan $\textcircled{1}$ ke dalam $\textcircled{3}: y = -3x + 21$
 Persamaan garis lurus: $y = -3x + 21$
 $x = 0.6, 6.4$

9. (a) $y = -x^2 + 2x + 9$

x	-3	2
y	-6	9

(b)

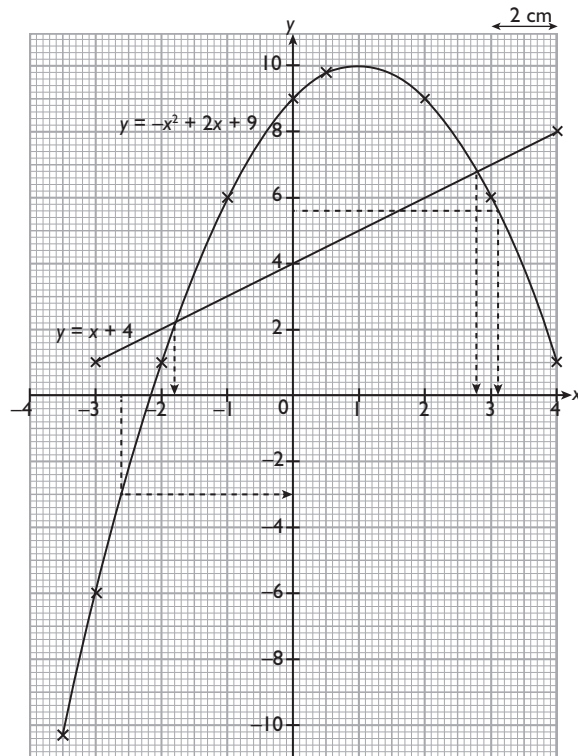

- (c) (i) -3
(ii) 3.1

(d) $y = -x^2 + 2x + 9 \dots \textcircled{1}$
 $0 = -x^2 + x + 5 \dots \textcircled{2}$
 $\textcircled{1} - \textcircled{2}: y = x + 4$
 Persamaan garis lurus: $y = x + 4$
 $x = -1.8, 2.8$

10. (a) $y = -x^3 + 5x + 11$

x	-2	1.5
y	9	15.1

(b)

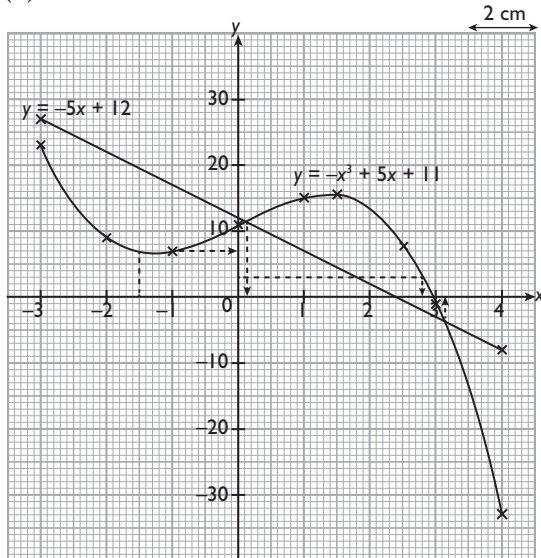

- (c) (i) 7
(ii) 2.8

(d) $y = -x^3 + 5x + 11 \dots \textcircled{1}$
 $0 = x^3 - 10x + 1 \dots \textcircled{2}$

$\textcircled{1} + \textcircled{2}: y = -5x + 12$

Persamaan garis lurus: $y = -5x + 12$

$x = 0.15, 3.15$

JAWAPAN

BAB 3: PENJELMAAN III

3.1

A

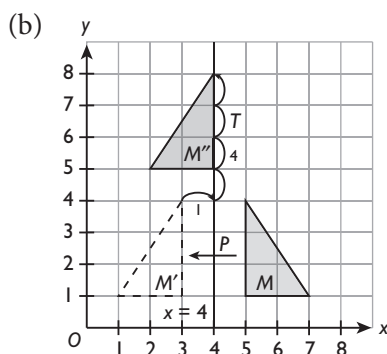
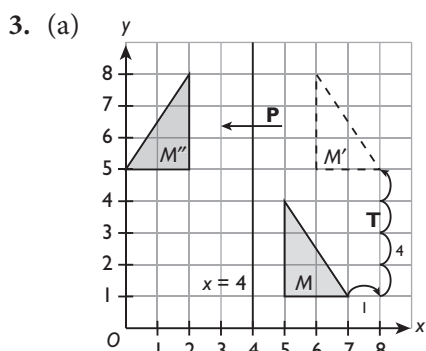
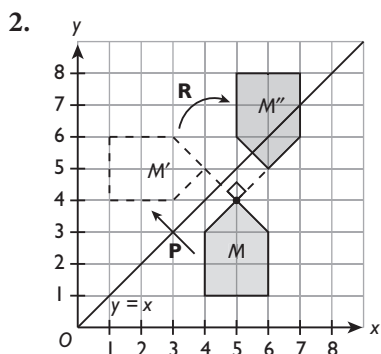
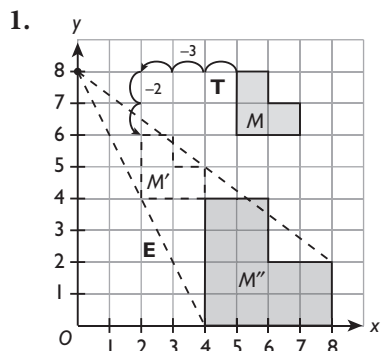

B

1. (a) $J \xrightarrow{\mathbf{P}} J' (7, 2) \xrightarrow{\mathbf{T}} J'' (4, 0)$

(b) $J \xrightarrow{\mathbf{T}} J' (4, 6) \xrightarrow{\mathbf{R}} J'' (3, 3)$

2. (a) $K \xrightarrow{\mathbf{T}} K' (4, 7) \xrightarrow{\mathbf{P}} K'' (4, 1)$

(b) $K \xrightarrow{\mathbf{P}} K' (2, 5) \xrightarrow{\mathbf{R}} K'' (8, 7)$

3. (a) $L \xrightarrow{\mathbf{T}} L' (2, 2) \xrightarrow{\mathbf{R}} L'' (1, 5)$

(b) $L \xrightarrow{\mathbf{R}} L' (-1, 6) \xrightarrow{\mathbf{P}} L'' (5, 6)$

4. (a) $M \xrightarrow{\mathbf{P}} M' (-4, 4) \xrightarrow{\mathbf{R}} M'' (-6, 2)$

(b) $M \xrightarrow{\mathbf{R}} M' (-6, 4) \xrightarrow{\mathbf{T}} M'' (-8, 7)$

5. (a) $N \xrightarrow{\mathbf{P}} N' (2, 5) \xrightarrow{\mathbf{R}} N'' (5, -2)$

(b) $N \xrightarrow{\mathbf{T}} N' (1, 5) \xrightarrow{\mathbf{T}} N'' (-3, 8)$

C

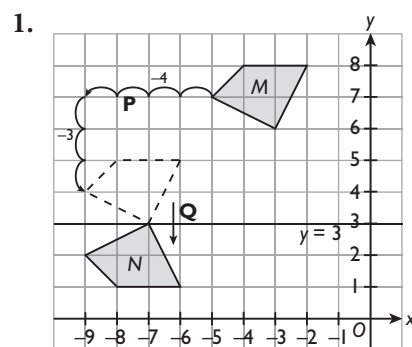

P: Satu translasi $\begin{pmatrix} -4 \\ -3 \end{pmatrix}$

A translation $\begin{pmatrix} -4 \\ -3 \end{pmatrix}$

Q: Satu pantulan pada garis $y = 3$
A reflection in the line $y = 3$

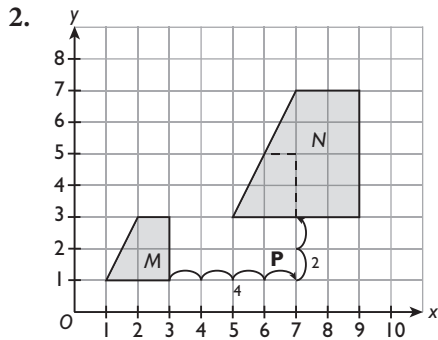

P: Satu translasi $\begin{pmatrix} 4 \\ 2 \end{pmatrix}$

A translation $\begin{pmatrix} 4 \\ 2 \end{pmatrix}$

Q: Satu pembesaran dengan faktor skala 2 pada pusat (5, 3)

An enlargement of scale factor 2 with centre (5, 3)

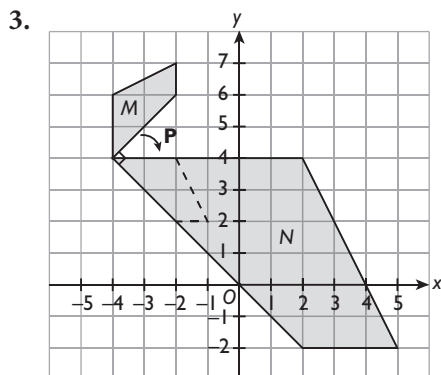

P: Satu putaran 90° ikut arah jam pada pusat (-4, 4)

A clockwise rotation of 90° about the centre (-4, 4)

Q: Satu pembesaran dengan faktor skala 3 pada pusat (-4, 4)

An enlargement of scale factor 3 with centre (-4, 4)

D

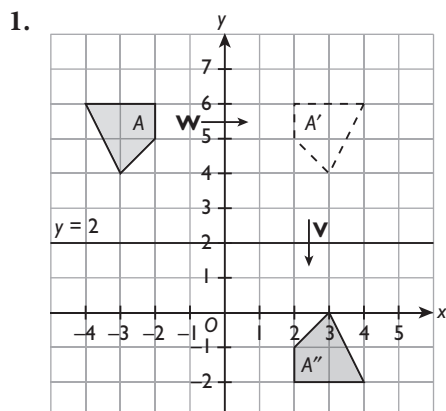

Penjelmaan tunggal yang setara dengan VW:
The single transformation which is equivalent to VW:

Satu putaran 180° pada pusat (0, 2)
A rotation of 180° about the centre (0, 2)

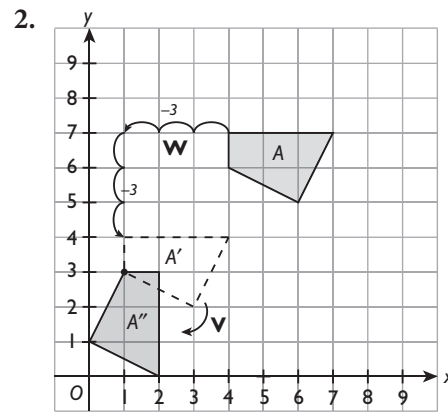

Penjelmaan tunggal yang setara dengan VW:
The single transformation which is equivalent to VW:

Satu putaran 90° ikut arah jam pada pusat (1, 6)
A clockwise rotation of 90° about the centre (1, 6)

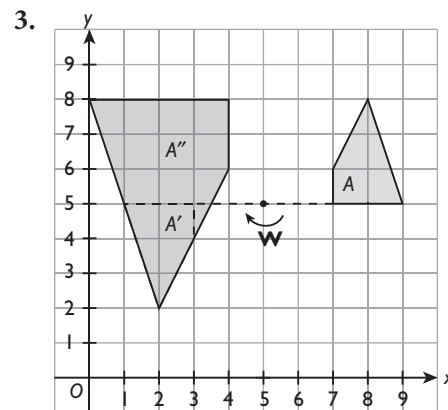

Penjelmaan tunggal yang setara dengan VW:
The single transformation which is equivalent to VW:

Satu pembesaran dengan faktor skala -2 pada pusat (6, 6)
An enlargement of scale factor -2 with centre (6, 6)

E

1. (a) (i) Q = Pantulan pada garis $y = 3$

(ii) Faktor skala, $k = \frac{BC}{JK} = \frac{2}{1} = 2$

P = Pembesaran dengan faktor skala 2 pada pusat A(3,4)

(b) Luas imej = $2^2 \times 16$
= 64 m^2

Luas kawasan berlerek = $64 - 16$
= 48 m^2

atau

Luas EFGH = $16 = 2.5 \text{ grid}$

Luas kawasan berlerek = $x = 7.5 \text{ grid}$

$$\frac{16}{x} = \frac{2.5}{7.5}$$

$$x = 48$$

Luas kawasan berlerek = 48 m^2

2. (a) (i) $W = \text{Translasi} \begin{pmatrix} 4 \\ -7 \end{pmatrix}$
(ii) Faktor skala
 $k = \frac{JM}{EH} = \frac{6}{3} = 2$
 $V = \text{Pembesaran dengan faktor skala 2 pada pusat } (0, -2)$

(b) Luas imej = $2^2 \times 5.5$
 $= 22 \text{ m}^2$
Luas kawasan berlorek = $22 - 5.5$
 $= 16.5 \text{ m}^2$

atau

Luas $ABCD = 5.5 = 6.5 \text{ grid}$
Luas kawasan berlorek = $x = 19.5 \text{ grid}$
 $\frac{5.5}{x} = \frac{6.5}{19.5}$
 $x = 16.5$
Luas kawasan berlorek = 16.5 m^2

3. (a) $M = \text{Putaran } 90^\circ \text{ ikut arah jam pada pusat } (-1, 5)$

Faktor skala,

$$k = \frac{KL}{GF} = \frac{3}{1} = 3$$

$N = \text{Pembesaran dengan faktor skala 3 pada pusat } E(-2, 2)$

(b) $x = \text{Luas } ABCD$
 $(120 + x) = 3^2 \times x$
 $120 + x = 9x$
 $8x = 120$
 $x = 15 \text{ cm}^2$

atau

Luas kawasan berlorek = $120 = 32 \text{ grid}$
Luas $ABCD = x = 4 \text{ grid}$
 $\frac{120}{x} = \frac{32}{4}$
 $x = 15$
Luas $ABCD = 15 \text{ cm}^2$

Praktis Formatif: Kertas 1

1. A

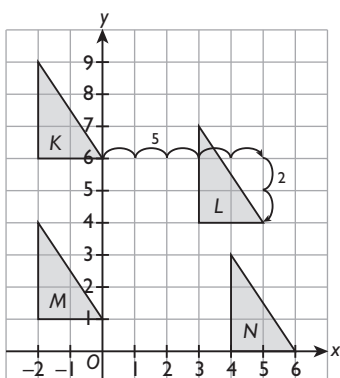

2. A

3. C

4. B

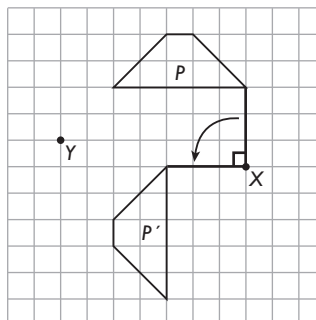

5. B

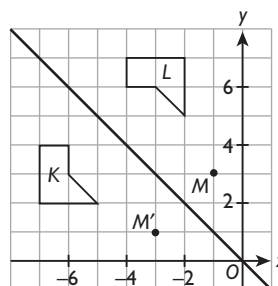

Koordinat imej titik $M = (-3, 1)$

6. C

7. B

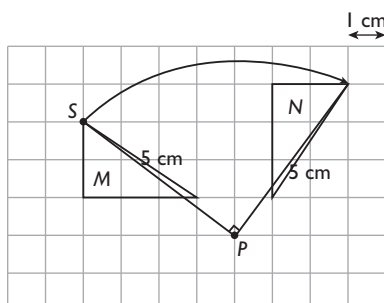

$$\text{Jarak} = \frac{1}{4} \times \frac{22}{7} \times 2 \times 5$$

$$= 7.86 \text{ cm}$$

8. C

$$\text{Luas imej} = k^2 \times \text{Luas objek}$$

$$= \left(\frac{1}{4}\right)^2 \times \frac{1}{2} \times 6 \times 5$$

$$= 3\frac{3}{4} \text{ cm}^2$$

$$\text{Luas imej} = \frac{1}{2} \times 3 \times 2.5$$

$$= 3\frac{3}{4} \text{ cm}^2$$

9. A

10. B

$$\begin{aligned}k^2 &= \frac{64\pi}{16\pi} \\ &= 4 \\ k &= \sqrt{4} \\ &= 2\end{aligned}$$

11. B

$$\begin{aligned}\text{Faktor skala} &= \frac{PW}{PS} \\ &= \frac{1}{3}\end{aligned}$$

12. A

$$\begin{aligned}\text{Faktor skala} &= -\frac{5}{2\,000} \\ &= -\frac{1}{400} \\ \text{Jarak} &= 10 \text{ cm} \div \frac{1}{400} \\ &= 10 \text{ cm} \times 400 \\ &= 4\,000 \text{ cm}\end{aligned}$$

13. A

$$\begin{aligned}\text{Jejari bulatan kecil} &= 9 \text{ cm} - 6 \text{ cm} \\ &= 3 \text{ cm} \\ \text{Faktor skala} &= \frac{9}{3} \\ &= 3\end{aligned}$$

14. D

15. A

16. C

Praktis Formatif: Kertas 2

1. (a) (i) $Q(4, 4) \xrightarrow{T} (-1, 2)$
(ii) $Q(4, 4) \xrightarrow{T} (-1, 2) \xrightarrow{R} (3, 2)$
- (b) (i) **V** = Putaran 90° ikut arah jam pada pusat $(0, 2)$
(ii) Faktor skala = $\frac{UV}{RS} = \frac{2}{1} = 2$
W = Pembesaran dengan faktor skala 2 pada pusat $P(1, 5)$
- (c) Katakan luas $PQRS = x \text{ m}^2$
 $x + 24 = 2^2 \times x \leftarrow \text{Luas imej} = k^2 \times \text{Luas objek}$
 $x + 24 = 4x$
 $3x = 24$
 $x = 8$
Luas $ABCD = \text{Luas } PQRS$
 $= 8 \text{ m}^2$

2. (a) (i) $A(1, 5) \xrightarrow{T} (5, 2) \xrightarrow{R} (3, 4)$
(ii) $A(1, 5) \xrightarrow{R} (0, 0) \xrightarrow{R} (5, -1)$
- (b) (i) (a) **W** = Pantulan pada garis $y = x$
(b) Faktor skala = $\frac{KM}{PS} = \frac{6}{3} = 2$
V = Pembesaran dengan faktor skala 2 pada pusat $R(5, 3)$
- (ii) Luas kawasan berlorek
 $= \text{Luas } LKMR - \text{Luas } QPSR$
 $= (2^2 \times 65) - 65 \leftarrow \begin{matrix} \text{Luas } QPSR \\ = \text{Luas } ABCD \end{matrix}$
 $= 260 - 65$
 $= 195 \text{ m}^2$

3. (a) (i) $P(2, 4) \xrightarrow{T} (5, 5) \xrightarrow{R} (-4, 6)$
(ii) $P(2, 4) \xrightarrow{R} (-3, 3) \xrightarrow{T} (0, 4)$
- (b) (i) (a) **W** = Pantulan pada garis $y = 2$
(b) Faktor skala = $\frac{PK}{PQ} = \frac{6}{2} = 3$
V = Pembesaran dengan faktor skala 3 pada pusat $P(1, 7)$
- (ii) Luas kawasan berlorek
 $= \text{Luas } PKLMN - \text{Luas } PQRST$
 $= (3^2 \times 36) - 36 \leftarrow \begin{matrix} \text{Luas } PQRST \\ = \text{Luas } ABCDE \end{matrix}$
 $= 324 - 36$
 $= 288 \text{ m}^2$

4. (a) (i) $A(-2.5, 3) \xrightarrow{T} (-2, 7) \xrightarrow{T} (-1.5, 11)$
(ii) $A(-2.5, 3) \xrightarrow{R} (1.5, 5) \xrightarrow{T} (2, 9)$
- (b) (i) (a) **N** = Pantulan pada garis $FCBE$
(b) Faktor skala = $\frac{FD}{CG} = \frac{6}{2} = 3$
M = Pembesaran dengan faktor skala 3 pada pusat $(-2, 2)$
- (ii) Luas kawasan berlorek
 $= \text{Luas } FDE - \text{Luas } BCG$
 $= (3^2 \times 28) - 28 \leftarrow \text{Luas } BCG = \text{Luas } CAB$
 $= 252 - 28$
 $= 224 \text{ m}^2$

5. (a) (i) $K(-7, 7) \xrightarrow{T} K'(-5, 4) \xrightarrow{T} K''(-3, 1)$
(ii) $K(-7, 7) \xrightarrow{P} K'(-7, 1) \xrightarrow{T} K''(-5, -2)$
- (b) (i) (a) **W** = Putaran 90° ikut arah jam pada pusat $(6, 8)$
(b) Faktor skala, $k = \frac{PT}{AE} = \frac{4}{2} = 2$
V = Pembesaran dengan faktor skala 2 pada pusat $P(5, 7)$
- (ii) **Kaedah 1:**
Luas objek $ABCDE = \frac{160}{2^2}$
 $= \frac{160}{4}$
 $= 40 \text{ m}^2$

Kaedah 2:

Luas $PQRST = 160 = 14 \text{ grid}$

Luas $ABCDE = x = 3.5 \text{ grid}$

$$\frac{160}{x} = \frac{14}{3.5}$$

$$x = 40$$

Luas $ABCDE = 40 \text{ m}^2$

6. (a) (i) $N(-7, 4) \xrightarrow{\mathbf{P}} N'(-3, 0) \xrightarrow{\mathbf{P}} N''(-7, 4)$
(ii)

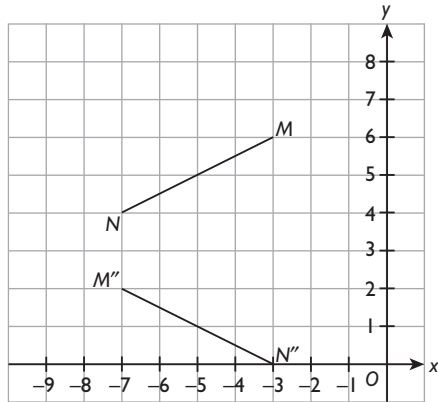

- (b) (i) (a) \mathbf{X} = Pantulan pada garis $x + y = 5$

- (b) Faktor skala, $k = \frac{7}{3}$

\mathbf{Y} = Pembesaran dengan faktor skala $\frac{7}{3}$ pada pusat $(1, 1)$

- (ii) Luas imej $R = \left(\frac{7}{3}\right)^2 \times 18$
 $= 98$

Luas kawasan berwarna hitam

$$= 98 + 18$$

$$= 116 \text{ cm}^2$$

JAWAPAN

BAB 4: MARIKS

4.1

A

1. $\begin{pmatrix} 3 \\ -8 \end{pmatrix}$	2. (4 -1 6)	3. $\begin{pmatrix} 4 & 2 & 1 \\ -3 & 9 & 2 \\ 6 & 0 & -5 \end{pmatrix}$
2	1	3
1	3	3
2×1	1×3	3×3

B

1. (a) $a_{23} = 9$
 (b) $a_{31} = -3$
 (c) $a_{22} = 7$
 (d) $a_{32} = 2$
 (e) $a_{21} = -6$
 (f) $a_{13} = 5$

2. (a) $p_{11} = 0$
 (b) $p_{22} = 4$
 (c) $p_{13} = 3$
 (d) $p_{21} = -2$
 (e) $p_{12} = -7$
 (f) $p_{23} = 0$

4.2

1. $x = 5$
 $-2y = -8$
 $y = 4$
 $5 + z = -3$
 $z = -5 - 3$
 $= -8$

2. $x = 6$
 $y = -3$
 $6z = -12$
 $z = -2$

3. $x + 2 = 8$
 $x = 6$
 $y - 1 = 6$
 $y = 7$
 $z = 4(7)$
 $= 28$

4.3

A

1. $\begin{pmatrix} 5 & -1 \\ 3 & 5 \end{pmatrix} + \begin{pmatrix} 4 & -2 \\ -6 & 7 \end{pmatrix}$
 $= \begin{pmatrix} 5+4 & -1-2 \\ 3-6 & 5+7 \end{pmatrix}$
 $= \begin{pmatrix} 9 & -3 \\ -3 & 12 \end{pmatrix}$

2. $\begin{pmatrix} -3 \\ 7 \end{pmatrix} + \begin{pmatrix} -1 \\ -2 \end{pmatrix}$
 $= \begin{pmatrix} -3-1 \\ 7-2 \end{pmatrix}$
 $= \begin{pmatrix} -4 \\ 5 \end{pmatrix}$

3. $\begin{pmatrix} 4 & 8 & 6 \\ -5 & -3 & 7 \end{pmatrix} - \begin{pmatrix} 9 & 2 & 8 \\ 4 & -6 & 10 \end{pmatrix}$
 $= \begin{pmatrix} 4-9 & 8-2 & 6-8 \\ -5-4 & -3+6 & 7-10 \end{pmatrix}$
 $= \begin{pmatrix} -5 & 6 & -2 \\ -9 & 3 & -3 \end{pmatrix}$

4. $\begin{pmatrix} 3 & 5 \\ 0 & 4 \end{pmatrix} - \begin{pmatrix} 6 & -1 \\ 3 & -2 \end{pmatrix}$
 $= \begin{pmatrix} 3-6 & 5+1 \\ 0-3 & 4+2 \end{pmatrix}$
 $= \begin{pmatrix} -3 & 6 \\ -3 & 6 \end{pmatrix}$

B

1. $(5 \ -2 \ 4) + (3 \ 6 \ 8) - (9 \ 7 \ -3)$
 $= (5+3-9 \ -2+6-7 \ 4+8+3)$
 $= (-1 \ -3 \ 15)$

2. $(3 \ -4) - (6 \ -7) + (-2 \ 5)$
 $= (3-6-2 \ -4+7+5)$
 $= (-5 \ 8)$

3. $\begin{pmatrix} 2 & 1 \\ 3 & -2 \end{pmatrix} + \begin{pmatrix} 1 & -4 \\ 5 & -7 \end{pmatrix} - \begin{pmatrix} 3 & -5 \\ -1 & 6 \end{pmatrix}$
 $= \begin{pmatrix} 2+1-3 & 1-4+5 \\ 3+5+1 & -2-7-6 \end{pmatrix}$
 $= \begin{pmatrix} 0 & 2 \\ 9 & -15 \end{pmatrix}$

$$4. \begin{pmatrix} 5 \\ 2 \end{pmatrix} - \begin{pmatrix} 2 \\ -4 \end{pmatrix} + \begin{pmatrix} -1 \\ 3 \end{pmatrix}$$

$$= \begin{pmatrix} 5 - 2 - 1 \\ 2 + 4 + 3 \end{pmatrix}$$

$$= \begin{pmatrix} 2 \\ 9 \end{pmatrix}$$

C

$$1. \begin{array}{l} 4 - y = 7 \\ y = 4 - 7 \\ = -3 \end{array} \quad \begin{array}{l} x - 2 = 2x \\ 2x - x = -2 \\ x = -2 \end{array}$$

$$2. \begin{array}{l} x - 5 = 10 \\ x = 15 \end{array} \quad \begin{array}{l} 4 - (-8) = 2y \\ 12 = 2y \\ y = 6 \end{array}$$

$$3. \begin{array}{l} 3x - 5 = 7 \\ 3x = 7 + 5 \\ 3x = 12 \\ x = 4 \end{array} \quad \begin{array}{l} 2 - 4y = 10 \\ -4y = 10 - 2 \\ -4y = 8 \\ y = -2 \end{array}$$

$$4. \begin{array}{l} 6x - 8 = -2 \\ 6x = -2 + 8 \\ 6x = 6 \\ x = 1 \end{array} \quad \begin{array}{l} -4 + 2y = 12 \\ 2y = 12 + 4 \\ 2y = 16 \\ y = 8 \end{array}$$

$$5. \begin{array}{l} 5y - 4 = 6 \\ 5y = 10 \\ y = 2 \end{array} \quad \begin{array}{l} x - y = 4 \\ x - 2 = 4 \\ x = 6 \end{array}$$

$$6. \begin{array}{l} x + 2 - 5 = -9 \\ x - 3 = -9 \\ x = -6 \end{array} \quad \begin{array}{l} -6 - 8 = -2y \\ -14 = -2y \\ y = 7 \end{array}$$

4.4

A

$$1. 4 \begin{pmatrix} -3 \\ 2 \end{pmatrix} = \begin{pmatrix} -12 \\ 8 \end{pmatrix}$$

$$2. -5(-1 \ 0 \ 3) = (5 \ 0 \ -15)$$

$$3. \frac{1}{6}(18 \ -12) = (3 \ -2)$$

$$4. \frac{1}{2} \begin{pmatrix} 10 & -6 & 0 \\ 2 & 4 & -8 \end{pmatrix} = \begin{pmatrix} 5 & -3 & 0 \\ 1 & 2 & -4 \end{pmatrix}$$

B

$$1. 2 \begin{pmatrix} -1 & 0 & 2 \\ 3 & -4 & 5 \end{pmatrix} + \frac{1}{4} \begin{pmatrix} 8 & 12 & -4 \\ 0 & 16 & -8 \end{pmatrix}$$

$$= \begin{pmatrix} -2 & 0 & 4 \\ 6 & -8 & 10 \end{pmatrix} + \begin{pmatrix} 2 & 3 & -1 \\ 0 & 4 & -2 \end{pmatrix}$$

$$= \begin{pmatrix} -2 + 2 & 0 + 3 & 4 - 1 \\ 6 + 0 & -8 + 4 & 10 - 2 \end{pmatrix}$$

$$= \begin{pmatrix} 0 & 3 & 3 \\ 6 & -4 & 8 \end{pmatrix}$$

$$2. \begin{pmatrix} 1 & -4 \\ 6 & 2 \\ -3 & 5 \end{pmatrix} - 3 \begin{pmatrix} -2 & 0 \\ 1 & 3 \\ 4 & -1 \end{pmatrix} = \begin{pmatrix} 1 & -4 \\ 6 & 2 \\ -3 & 5 \end{pmatrix} - \begin{pmatrix} -6 & 0 \\ 3 & 9 \\ 12 & -3 \end{pmatrix}$$

$$= \begin{pmatrix} 1 + 6 & -4 + 0 \\ 6 - 3 & 2 - 9 \\ -3 - 12 & 5 + 3 \end{pmatrix}$$

$$= \begin{pmatrix} 7 & -4 \\ 3 & -7 \\ -15 & 8 \end{pmatrix}$$

$$3. 5 \begin{pmatrix} 1 \\ 0 \\ -2 \end{pmatrix} - \frac{1}{3} \begin{pmatrix} 12 \\ 6 \\ -9 \end{pmatrix} = \begin{pmatrix} 5 \\ 0 \\ -10 \end{pmatrix} - \begin{pmatrix} 4 \\ 2 \\ -3 \end{pmatrix}$$

$$= \begin{pmatrix} 5 - 4 \\ 0 - 2 \\ -10 + 3 \end{pmatrix}$$

$$= \begin{pmatrix} 1 \\ -2 \\ -7 \end{pmatrix}$$

$$4. \frac{1}{2}(4 \ -8) + 5(1 \ 0) = (2 \ -4) + (5 \ 0)$$

$$= (2 + 5 \ -4 + 0)$$

$$= (7 \ -4)$$

$$5. 2(-1 \ 3 \ -2) - \frac{1}{8}(0 \ -16 \ 8)$$

$$= (-2 \ 6 \ -4) - (0 \ -2 \ 1)$$

$$= (-2 - 0 \ 6 + 2 \ -4 - 1)$$

$$= (-2 \ 8 \ -5)$$

C

$$1. -2\mathbf{Q} + \frac{1}{3}\mathbf{R} - \mathbf{P}$$

$$= -2 \begin{pmatrix} 1 & 7 \\ 0 & -3 \end{pmatrix} + \frac{1}{3} \begin{pmatrix} -9 & 6 \\ -3 & 12 \end{pmatrix} - \begin{pmatrix} -2 & 48 \\ 10 & \end{pmatrix}$$

$$= \begin{pmatrix} -2 & -14 \\ 0 & 6 \end{pmatrix} + \begin{pmatrix} -3 & 2 \\ -1 & 4 \end{pmatrix} - \begin{pmatrix} -2 & 4 \\ 10 & -8 \end{pmatrix}$$

$$= \begin{pmatrix} -2 - 3 + 2 & -14 + 2 - 4 \\ 0 - 1 - 10 & 6 + 4 + 8 \end{pmatrix}$$

$$= \begin{pmatrix} -3 & -16 \\ -11 & 18 \end{pmatrix}$$

$$2. \frac{1}{2}\mathbf{P} - \mathbf{R} + 3\mathbf{Q}$$

$$= \frac{1}{2} \begin{pmatrix} -2 & 48 \\ 10 & \end{pmatrix} - \begin{pmatrix} -9 & 6 \\ -3 & 12 \end{pmatrix} + 3 \begin{pmatrix} 1 & 7 \\ 0 & -3 \end{pmatrix}$$

$$= \begin{pmatrix} -1 & 2 \\ 5 & -4 \end{pmatrix} - \begin{pmatrix} -9 & 6 \\ -3 & 12 \end{pmatrix} + \begin{pmatrix} 3 & 21 \\ 0 & -9 \end{pmatrix}$$

$$= \begin{pmatrix} -1 + 9 + 3 & 2 - 6 + 21 \\ 5 + 3 + 0 & -4 - 12 - 9 \end{pmatrix}$$

$$= \begin{pmatrix} 11 & 17 \\ 8 & -25 \end{pmatrix}$$

D

$$1. 2 \begin{pmatrix} 4 \\ y \end{pmatrix} + \begin{pmatrix} x \\ 8 \end{pmatrix} = \begin{pmatrix} 10 \\ 18 \end{pmatrix}$$

$$\begin{pmatrix} 8 \\ 2y \end{pmatrix} + \begin{pmatrix} x \\ 8 \end{pmatrix} = \begin{pmatrix} 10 \\ 18 \end{pmatrix}$$

$$\begin{aligned} 8 + x &= 10 & 2y + 8 &= 18 \\ x &= 2 & 2y &= 10 \\ & & y &= 5 \end{aligned}$$

$$2. 3 \begin{pmatrix} 4 & x \\ y & 2 \end{pmatrix} - 3 \begin{pmatrix} 6 & -2x \\ 7 & -8 \end{pmatrix} = \begin{pmatrix} -6 & 18 \\ 6y & 30 \end{pmatrix}$$

$$\begin{pmatrix} 12 & 3x \\ 3y & 6 \end{pmatrix} - \begin{pmatrix} 18 & -6x \\ 21 & -24 \end{pmatrix} = \begin{pmatrix} -6 & 18 \\ 6y & 30 \end{pmatrix}$$

$$\begin{aligned} 3x + 6x &= 18 & 3y - 21 &= 6y \\ 9x &= 18 & 3y &= -21 \\ x &= 2 & y &= -7 \end{aligned}$$

$$3. \frac{1}{3} \begin{pmatrix} x & 12 \\ 6 & 9 \end{pmatrix} - 4 \begin{pmatrix} 1 & 2 \\ 0 & 5 \end{pmatrix} = \begin{pmatrix} 1 & -4 \\ y & -17 \end{pmatrix}$$

$$\frac{1}{3} \begin{pmatrix} x & 12 \\ 6 & 9 \end{pmatrix} - \begin{pmatrix} 4 & 8 \\ 0 & 20 \end{pmatrix} = \begin{pmatrix} 1 & -4 \\ y & -17 \end{pmatrix}$$

$$\begin{aligned} \frac{1}{3}x - 4 &= 1 & \frac{1}{3}(6) - 0 &= y \\ \frac{1}{3}x &= 5 & 2 - 0 &= y \\ x &= 15 & y &= 2 \end{aligned}$$

$$4. \begin{pmatrix} x \\ -1 \\ 3 \end{pmatrix} - 3 \begin{pmatrix} 5 \\ 0 \\ 2 \end{pmatrix} = \frac{1}{5} \begin{pmatrix} 15 \\ -5 \\ y \end{pmatrix}$$

$$\begin{pmatrix} x \\ -1 \\ 3 \end{pmatrix} - \begin{pmatrix} 15 \\ 0 \\ 6 \end{pmatrix} = \frac{1}{5} \begin{pmatrix} 15 \\ -5 \\ y \end{pmatrix}$$

$$\begin{aligned} x - 15 &= \frac{1}{5}(15) & 3 - 6 &= \frac{1}{5}y \\ x - 15 &= 3 & \frac{1}{5}y &= -3 \\ x &= 18 & y &= -15 \end{aligned}$$

$$5. -2(5 \ x \ 3) - \frac{1}{4}(8 \ -4 \ 12) = 3(-4 \ 5 \ y)$$

$$(-10 \ -2x \ -6) - (2 \ -1 \ 3) = (-12 \ 15 \ 3y)$$

$$\begin{aligned} -2x + 1 &= 15 & -6 - 3 &= 3y \\ -2x &= 14 & 3y &= -9 \\ x &= -7 & y &= -3 \end{aligned}$$

4.5**A**

$$1. \begin{pmatrix} 2 & 1 & -3 \\ 4 & 5 & 1 \end{pmatrix} \begin{pmatrix} -4 \\ 7 \end{pmatrix}$$

Peringkat: $(2 \times 3)(2 \times 1)$

↑ ↑
Tidak sama

∴ Tidak boleh didarab

$$2. \begin{pmatrix} -4 \\ -3 \end{pmatrix} (5 \ -2)$$

Peringkat: $(2 \times 1)(1 \times 2)$

↑ ↑
Sama

∴ Boleh didarab

Peringkat matriks yang terhasil = 2×2

$$3. (-5 \ 2) \begin{pmatrix} 0 & 4 \\ -1 & 3 \end{pmatrix}$$

Peringkat: $(1 \times 2)(2 \times 2)$

↑ ↑
Sama

∴ Boleh didarab

Peringkat matriks yang terhasil = 1×2

B

$$1. (-4 \ 3) \begin{pmatrix} 1 \\ 5 \end{pmatrix} = (-4(1) + 3(5))$$

$$\begin{aligned} &= (-4 + 15) \\ &= (11) \end{aligned}$$

$$2. \begin{pmatrix} 2 \\ -3 \end{pmatrix} (5 \ 4) = \begin{pmatrix} 2 \times 5 & 2 \times 4 \\ -3 \times 5 & -3 \times 4 \end{pmatrix}$$

$$= \begin{pmatrix} 10 & 8 \\ -15 & -12 \end{pmatrix}$$

$$3. (2 \ -1 \ 4) \begin{pmatrix} 1 \\ 3 \\ -2 \end{pmatrix} = (2(1) + (-1)(3) + 4(-2))$$

$$\begin{aligned} &= (2 - 3 - 8) \\ &= (-9) \end{aligned}$$

$$4. (-3 \ 4) \begin{pmatrix} 0 & -5 \\ 2 & 1 \end{pmatrix} = (-3(0) + 4(2) \ -3(-5) + 4(1))$$

$$= (8 \ 19)$$

$$5. \begin{pmatrix} 5 & 1 \\ -3 & 0 \end{pmatrix} \begin{pmatrix} 4 \\ 2 \end{pmatrix} = \begin{pmatrix} 5(4) + 1(2) \\ -3(4) + 0(2) \end{pmatrix}$$

$$= \begin{pmatrix} 22 \\ -12 \end{pmatrix}$$

$$6. \begin{pmatrix} -6 & 2 \\ 4 & 3 \end{pmatrix} \begin{pmatrix} 1 & -2 \\ 7 & 5 \end{pmatrix}$$

$$= \begin{pmatrix} -6(1) + 2(7) & -6(-2) + 2(5) \\ 4(1) + 3(7) & 4(-2) + 3(5) \end{pmatrix}$$

$$= \begin{pmatrix} 8 & 22 \\ 25 & 7 \end{pmatrix}$$

$$7. \begin{pmatrix} 5 & -3 \\ -4 & 2 \end{pmatrix} \begin{pmatrix} 2 & -1 \\ 3 & 6 \end{pmatrix}$$

$$= \begin{pmatrix} 5(2) + (-3)(3) & 5(-1) + (-3)(6) \\ -4(2) + 2(3) & -4(-1) + 2(6) \end{pmatrix}$$

$$= \begin{pmatrix} 1 & -23 \\ -2 & 16 \end{pmatrix}$$

$$\begin{aligned}
 8. \quad & \begin{pmatrix} -1 & 3 \\ 2 & 5 \\ 4 & 0 \end{pmatrix} \begin{pmatrix} -3 & 4 \\ 1 & 2 \end{pmatrix} \\
 & = \begin{pmatrix} -1(-3) + 3(1) & -1(4) + 3(2) \\ 2(-3) + 5(1) & 2(4) + 5(2) \\ 4(-3) + 0(1) & 4(4) + 0(2) \end{pmatrix} \\
 & = \begin{pmatrix} 6 & 2 \\ -1 & 18 \\ -12 & 16 \end{pmatrix}
 \end{aligned}$$

C

$$\begin{aligned}
 1. \quad & \begin{pmatrix} 3 \\ x \end{pmatrix} \begin{pmatrix} y & 4 \end{pmatrix} = \begin{pmatrix} 18 & 12 \\ -12 & -8 \end{pmatrix} \\
 & \begin{pmatrix} 3y & 3(4) \\ xy & 4x \end{pmatrix} = \begin{pmatrix} 18 & 12 \\ -12 & -8 \end{pmatrix} \\
 & \quad \quad \quad 4x = -8 \quad \quad 3y = 18 \\
 & \quad \quad \quad x = -2 \quad \quad y = 6
 \end{aligned}$$

$$\begin{aligned}
 2. \quad & \begin{pmatrix} 2x \\ -1 \end{pmatrix} \begin{pmatrix} 6 & -2 \end{pmatrix} = \begin{pmatrix} 3 & -1 \\ -6 & y \end{pmatrix} \\
 & \begin{pmatrix} 12x & -4x \\ -6 & 2 \end{pmatrix} = \begin{pmatrix} 3 & -1 \\ -6 & y \end{pmatrix} \\
 & \quad \quad \quad 12x = 3 \quad \quad y = 2 \\
 & \quad \quad \quad x = \frac{1}{4}
 \end{aligned}$$

$$\begin{aligned}
 3. \quad & (x \ 1) \begin{pmatrix} 2 & -1 \\ -3 & 4 \end{pmatrix} = (5 \ y) \\
 & (2x - 3 \ -x + 4) = (5 \ y) \\
 & \quad \quad \quad 2x - 3 = 5 \quad \quad -x + 4 = y \\
 & \quad \quad \quad 2x = 8 \quad \quad \quad y = -4 + 4 \\
 & \quad \quad \quad x = 4 \quad \quad \quad \quad = 0
 \end{aligned}$$

$$\begin{aligned}
 4. \quad & (-2 \ 4 \ 0) \begin{pmatrix} x & -1 \\ -3 & y \\ 1 & -5 \end{pmatrix} = (-8 \ 4) \\
 & (-2x - 12 + 0 \ 2 + 4y + 0) = (-8 \ 4) \\
 & \quad \quad \quad -2x - 12 = -8 \quad \quad 2 + 4y = 4 \\
 & \quad \quad \quad -2x = 4 \quad \quad \quad 4y = 2 \\
 & \quad \quad \quad x = -2 \quad \quad \quad y = \frac{1}{2}
 \end{aligned}$$

$$\begin{aligned}
 5. \quad & \begin{pmatrix} 2 & 3 \\ -1 & 1 \end{pmatrix} \begin{pmatrix} 6 & 3 \\ 0 & -2 \end{pmatrix} = \begin{pmatrix} x & y \\ -6 & -5 \end{pmatrix} \\
 & \begin{pmatrix} 2(6) + 3(0) & 2(3) + 3(-2) \\ -1(6) + 1(0) & -1(3) + 1(-2) \end{pmatrix} = \begin{pmatrix} x & y \\ -6 & -5 \end{pmatrix} \\
 & \quad \quad \quad \begin{pmatrix} 12 & 0 \\ -6 & -5 \end{pmatrix} = \begin{pmatrix} x & y \\ -6 & -5 \end{pmatrix} \\
 & \quad \quad \quad x = 12, y = 0
 \end{aligned}$$

$$\begin{aligned}
 6. \quad & \begin{pmatrix} 0 & -2 \\ y & 1 \end{pmatrix} \begin{pmatrix} 5 & 3 \\ 4 & -2 \end{pmatrix} = \begin{pmatrix} x & 4 \\ 14 & 4 \end{pmatrix} \\
 & \begin{pmatrix} 0(5) + (-2)(4) & 0(3) + (-2)(-2) \\ 5y + 1(4) & 3y + 1(-2) \end{pmatrix} = \begin{pmatrix} x & 4 \\ 14 & 4 \end{pmatrix} \\
 & \quad \quad \quad 0 - 8 = x \quad \quad 5y + 4 = 14 \\
 & \quad \quad \quad x = -8 \quad \quad \quad 5y = 10 \\
 & \quad \quad \quad \quad \quad \quad y = 2
 \end{aligned}$$

$$\begin{aligned}
 7. \quad & \begin{pmatrix} x & 1 \\ -2 & 3 \end{pmatrix} \begin{pmatrix} 2 & 1 \\ 4 & y \end{pmatrix} = \begin{pmatrix} 10 & 8 \\ 8 & 13 \end{pmatrix} \\
 & \begin{pmatrix} 2x + 1(4) & x + y \\ -2(2) + 3(4) & -2 + 3y \end{pmatrix} = \begin{pmatrix} 10 & 8 \\ 8 & 13 \end{pmatrix} \\
 & \quad \quad \quad 2x + 4 = 10 \quad \quad -2 + 3y = 13 \\
 & \quad \quad \quad 2x = 6 \quad \quad \quad 3y = 15 \\
 & \quad \quad \quad x = 3 \quad \quad \quad y = 5
 \end{aligned}$$

$$\begin{aligned}
 8. \quad & \begin{pmatrix} -1 & 3 \\ 2 & x \end{pmatrix} \begin{pmatrix} y & 3 \\ 2 & 4 \end{pmatrix} = \begin{pmatrix} -7 & 9 \\ 20 & -6 \end{pmatrix} \\
 & \begin{pmatrix} -y + 3(2) & -3 + 3(4) \\ 2y + 2x & 2(3) + 4x \end{pmatrix} = \begin{pmatrix} -7 & 9 \\ 20 & -6 \end{pmatrix} \\
 & \quad \quad \quad -y + 6 = -7 \quad \quad 6 + 4x = -6 \\
 & \quad \quad \quad -y = -13 \quad \quad \quad 4x = -12 \\
 & \quad \quad \quad y = 13 \quad \quad \quad x = -3
 \end{aligned}$$

4.6

$$\begin{aligned}
 1. \quad & \begin{pmatrix} 4 & -1 & 3 \\ 2 & 0 & -5 \\ 3 & 7 & -2 \end{pmatrix} - \begin{pmatrix} 1 & 0 & 0 \\ 0 & 1 & 0 \\ 0 & 0 & 1 \end{pmatrix} \begin{pmatrix} 3 & 0 & 5 \\ 2 & 4 & 1 \\ -1 & 2 & 6 \end{pmatrix} \\
 & = \begin{pmatrix} 4-3 & -1-0 & 3-5 \\ 2-2 & 0-4 & -5-1 \\ 3+1 & 7-2 & -2-6 \end{pmatrix} = \begin{pmatrix} 1 & -1 & -2 \\ 0 & -4 & -6 \\ 4 & 5 & -8 \end{pmatrix}
 \end{aligned}$$

$$\begin{aligned}
 2. \quad & 3 \begin{pmatrix} 1 & 0 \\ 0 & 1 \end{pmatrix} \begin{pmatrix} 3 & -2 \\ 1 & 5 \end{pmatrix} + \begin{pmatrix} 1 & 0 \\ -4 & -8 \end{pmatrix} \\
 & = \begin{pmatrix} 9 & -6 \\ 3 & 15 \end{pmatrix} + \begin{pmatrix} 1 & 0 \\ -4 & -8 \end{pmatrix} \\
 & = \begin{pmatrix} 9+1 & -6+0 \\ 3-4 & 15-8 \end{pmatrix} = \begin{pmatrix} 10 & -6 \\ -1 & 7 \end{pmatrix}
 \end{aligned}$$

4.7

A

$$\begin{aligned}
 1. \quad & \mathbf{P}^{-1} = \frac{1}{2(4) - 1(7)} \begin{pmatrix} 4 & -1 \\ -7 & 2 \end{pmatrix} \\
 & = \frac{1}{1} \begin{pmatrix} 4 & -1 \\ -7 & 2 \end{pmatrix} \\
 & = \begin{pmatrix} 4 & -1 \\ -7 & 2 \end{pmatrix}
 \end{aligned}$$

$$\begin{aligned}
 2. \quad & \mathbf{Q}^{-1} = \frac{1}{-5(4) - 8(-3)} \begin{pmatrix} 4 & -8 \\ 3 & -5 \end{pmatrix} \\
 & = \frac{1}{4} \begin{pmatrix} 4 & -8 \\ 3 & -5 \end{pmatrix} \text{ atau } \begin{pmatrix} 1 & -2 \\ \frac{3}{4} & -\frac{5}{4} \end{pmatrix}
 \end{aligned}$$

$$3. \mathbf{R}^{-1} = \frac{1}{4(-3) - (-2)(5)} \begin{pmatrix} -3 & 2 \\ -5 & 4 \end{pmatrix}$$

$$= -\frac{1}{2} \begin{pmatrix} -3 & 2 \\ -5 & 4 \end{pmatrix} \text{ atau } \begin{pmatrix} \frac{3}{2} & -1 \\ \frac{5}{2} & -2 \end{pmatrix}$$

$$4. \mathbf{S}^{-1} = \frac{1}{3(3) - 2(6)} \begin{pmatrix} 3 & -2 \\ -6 & 3 \end{pmatrix}$$

$$= -\frac{1}{3} \begin{pmatrix} 3 & -2 \\ -6 & 3 \end{pmatrix} \text{ atau } \begin{pmatrix} -1 & \frac{2}{3} \\ 2 & -1 \end{pmatrix}$$

B

$$1. \mathbf{B} = \begin{pmatrix} 3 & 5 \\ 2 & 3 \end{pmatrix}^{-1}$$

$$= \frac{1}{3(3) - 5(2)} \begin{pmatrix} 3 & -5 \\ -2 & 3 \end{pmatrix}$$

$$= \frac{1}{-1} \begin{pmatrix} 3 & -5 \\ -2 & 3 \end{pmatrix}$$

$$= \begin{pmatrix} -3 & 5 \\ 2 & -3 \end{pmatrix}$$

$$2. \mathbf{C} = \begin{pmatrix} -7 & -2 \\ 6 & 2 \end{pmatrix}^{-1}$$

$$= \frac{1}{-7(2) - (-2)(6)} \begin{pmatrix} 2 & 2 \\ -6 & -7 \end{pmatrix}$$

$$= -\frac{1}{2} \begin{pmatrix} 2 & 2 \\ -6 & -7 \end{pmatrix} \text{ atau } \begin{pmatrix} -1 & -1 \\ 3 & \frac{7}{2} \end{pmatrix}$$

$$3. m \begin{pmatrix} -4 & p \\ -3 & 5 \end{pmatrix} = \begin{pmatrix} 5 & -7 \\ 3 & -4 \end{pmatrix}^{-1}$$

$$= \frac{1}{5(-4) - (-7)(3)} \begin{pmatrix} -4 & 7 \\ -3 & 5 \end{pmatrix}$$

$$\therefore p = 7, \quad m = \frac{1}{-20 + 21} = 1$$

$$4. \frac{1}{k} \begin{pmatrix} 8 & -2 \\ -3 & m \end{pmatrix} = \begin{pmatrix} 1 & 2 \\ 3 & 8 \end{pmatrix}^{-1}$$

$$= \frac{1}{1(8) - 2(3)} \begin{pmatrix} 8 & -2 \\ -3 & 1 \end{pmatrix}$$

$$\therefore m = 1, \quad k = \frac{8 - 6}{2} = 1$$

$$5. \frac{1}{2} \begin{pmatrix} 4 & -2 \\ -13 & h \end{pmatrix} = \begin{pmatrix} h & 2 \\ 13 & k \end{pmatrix}^{-1}$$

$$= \frac{1}{hk - 2(13)} \begin{pmatrix} k & -2 \\ -13 & h \end{pmatrix}$$

$$\therefore k = 4, \quad hk - 26 = 2$$

$$4h = 28$$

$$h = 7$$

4.8

A

$$1. \begin{aligned} -2x + 3y &= 13 \\ 3x - 4y &= -18 \end{aligned}$$

$$\begin{pmatrix} -2 & 3 \\ 3 & -4 \end{pmatrix} \begin{pmatrix} x \\ y \end{pmatrix} = \begin{pmatrix} 13 \\ -18 \end{pmatrix}$$

$$\begin{pmatrix} x \\ y \end{pmatrix} = \frac{1}{-2(-4) - 3(3)} \begin{pmatrix} -4 & -3 \\ -3 & -2 \end{pmatrix} \begin{pmatrix} 13 \\ -18 \end{pmatrix}$$

$$= \frac{1}{8 - 9} \begin{pmatrix} -4(13) + (-3)(-18) \\ -3(13) + (-2)(-18) \end{pmatrix}$$

$$= \frac{1}{-1} \begin{pmatrix} 2 \\ -3 \end{pmatrix}$$

$$= \begin{pmatrix} -2 \\ 3 \end{pmatrix}$$

$$\therefore x = -2, y = 3$$

$$2. \begin{aligned} -3x + 5y &= -18 \\ x - 3y &= 10 \end{aligned}$$

$$\begin{pmatrix} -3 & 5 \\ 1 & -3 \end{pmatrix} \begin{pmatrix} x \\ y \end{pmatrix} = \begin{pmatrix} -18 \\ 10 \end{pmatrix}$$

$$\begin{pmatrix} x \\ y \end{pmatrix} = \frac{1}{-3(-3) - 5(1)} \begin{pmatrix} -3 & -5 \\ -1 & -3 \end{pmatrix} \begin{pmatrix} -18 \\ 10 \end{pmatrix}$$

$$= \frac{1}{9 - 5} \begin{pmatrix} -3(-18) + (-5)(10) \\ -1(-18) + (-3)(10) \end{pmatrix}$$

$$= \frac{1}{4} \begin{pmatrix} 4 \\ -12 \end{pmatrix} = \begin{pmatrix} 1 \\ -3 \end{pmatrix}$$

$$\therefore x = 1, y = -3$$

$$3. \begin{aligned} x &= 5y - 8 \Rightarrow x - 5y = -8 \\ 3x - 2y &= -11 \end{aligned}$$

$$\begin{pmatrix} 1 & -5 \\ 3 & -2 \end{pmatrix} \begin{pmatrix} x \\ y \end{pmatrix} = \begin{pmatrix} -8 \\ -11 \end{pmatrix}$$

$$\begin{pmatrix} x \\ y \end{pmatrix} = \frac{1}{1(-2) - (-5)(3)} \begin{pmatrix} -2 & 5 \\ -3 & 1 \end{pmatrix} \begin{pmatrix} -8 \\ -11 \end{pmatrix}$$

$$= \frac{1}{-2 + 15} \begin{pmatrix} -2(-8) + 5(-11) \\ -3(-8) + 1(-11) \end{pmatrix}$$

$$= \frac{1}{13} \begin{pmatrix} -39 \\ 13 \end{pmatrix} = \begin{pmatrix} -3 \\ 1 \end{pmatrix}$$

$$\therefore x = -3, y = 1$$

B

Katakan harga sebatang pen ialah RMx dan harga sebiji pemadam ialah RMy.

$$\begin{aligned} 2x - 3y &= 5 \\ 3x + 4y &= 16 \end{aligned}$$

$$\begin{pmatrix} 2 & -3 \\ 3 & 4 \end{pmatrix} \begin{pmatrix} x \\ y \end{pmatrix} = \begin{pmatrix} 5 \\ 16 \end{pmatrix}$$

$$\begin{pmatrix} x \\ y \end{pmatrix} = \frac{1}{2(4) - (-3)(3)} \begin{pmatrix} 4 & 3 \\ -3 & 2 \end{pmatrix} \begin{pmatrix} 5 \\ 16 \end{pmatrix}$$

$$= \frac{1}{17} \begin{pmatrix} 20 + 48 \\ -15 + 32 \end{pmatrix}$$

$$= \frac{1}{17} \begin{pmatrix} 68 \\ 17 \end{pmatrix} = \begin{pmatrix} 4 \\ 1 \end{pmatrix}$$

\therefore Harga sebatang pen = RM4
 Harga sebiji pemadam = RM1

Praktis Formatif: Kertas 1

1. A

$$\begin{pmatrix} 6 & 2 \\ 7 & 5 \end{pmatrix} + \begin{pmatrix} 3 & 7 \\ 6 & 5 \end{pmatrix} - \begin{pmatrix} 5 & 4 \\ 3 & 9 \end{pmatrix} + \begin{pmatrix} 1 & 5 \\ 7 & 8 \end{pmatrix}$$

$$= \begin{pmatrix} 6+3-5+1 & 2+7-4+5 \\ 7+6-3+7 & 5+5-9+8 \end{pmatrix}$$

$$= \begin{pmatrix} 5 & 10 \\ 17 & 9 \end{pmatrix}$$

2. D

$$\mathbf{P} + \begin{pmatrix} -2 & 4 \\ 3 & 2 \end{pmatrix} = \begin{pmatrix} 3 & 5 \\ 2 & 0 \end{pmatrix}$$

$$\mathbf{P} = \begin{pmatrix} 3 & 5 \\ 2 & 0 \end{pmatrix} - \begin{pmatrix} -2 & 4 \\ 3 & 2 \end{pmatrix}$$

$$= \begin{pmatrix} 5 & 1 \\ -1 & -2 \end{pmatrix}$$

3. B

$$\begin{pmatrix} 14 & 0 \\ 7 & -6 \end{pmatrix} - 2\mathbf{Q} = 5 \begin{pmatrix} 2 & -\frac{4}{5} \\ 3 & -4 \end{pmatrix}$$

$$2\mathbf{Q} = \begin{pmatrix} 14 & 0 \\ 7 & -6 \end{pmatrix} - \begin{pmatrix} 10 & -4 \\ 15 & -20 \end{pmatrix}$$

$$= \begin{pmatrix} 4 & 4 \\ -8 & 14 \end{pmatrix}$$

$$\mathbf{Q} = \frac{1}{2} \begin{pmatrix} 4 & 4 \\ -8 & 14 \end{pmatrix}$$

$$= \begin{pmatrix} 2 & 2 \\ -4 & 7 \end{pmatrix}$$

4. B

$$\begin{pmatrix} 6 & -3 & 4 \\ 2 & 5 & -1 \end{pmatrix} - \begin{pmatrix} 2 & 5 & -1 \\ -2 & 3 & 7 \end{pmatrix} + 3 \begin{pmatrix} -2 & 3 & 7 \\ -6 & 9 & 21 \end{pmatrix}$$

$$= \begin{pmatrix} 6 & -3 & 4 \\ 2 & 5 & -1 \end{pmatrix} - \begin{pmatrix} 2 & 5 & -1 \\ -2 & 3 & 7 \end{pmatrix} + \begin{pmatrix} -6 & 9 & 21 \\ -18 & 27 & 63 \end{pmatrix}$$

$$= \begin{pmatrix} -2 & 1 & 26 \end{pmatrix}$$

5. C

$$\begin{pmatrix} 3 \\ 2 \end{pmatrix} - \begin{pmatrix} 4 \\ -5 \end{pmatrix} + \frac{1}{3} \begin{pmatrix} -9 \\ -6 \end{pmatrix}$$

$$= \begin{pmatrix} 3 \\ 2 \end{pmatrix} - \begin{pmatrix} 4 \\ -5 \end{pmatrix} + \begin{pmatrix} -3 \\ -2 \end{pmatrix}$$

$$= \begin{pmatrix} -4 \\ 5 \end{pmatrix}$$

6. D

$$\begin{pmatrix} -4 \\ 3 \end{pmatrix} + \begin{pmatrix} -2 \\ 5 \end{pmatrix} + 2 \begin{pmatrix} -3 \\ 4 \end{pmatrix} = \begin{pmatrix} -4 \\ 3 \end{pmatrix} + \begin{pmatrix} -2 \\ 5 \end{pmatrix} + \begin{pmatrix} -6 \\ 8 \end{pmatrix}$$

$$= \begin{pmatrix} -12 \\ 16 \end{pmatrix}$$

7. D

$$\begin{pmatrix} 5 & 2 \\ 7 & 1 \end{pmatrix} + 3 \begin{pmatrix} 4 & 0 \\ 5 & -2 \end{pmatrix} - \begin{pmatrix} -2 & 4 \\ -1 & 5 \end{pmatrix}$$

$$= \begin{pmatrix} 5 & 2 \\ 7 & 1 \end{pmatrix} + \begin{pmatrix} 12 & 0 \\ 15 & -6 \end{pmatrix} - \begin{pmatrix} -2 & 4 \\ -1 & 5 \end{pmatrix}$$

$$= \begin{pmatrix} 19 & -2 \\ 23 & -10 \end{pmatrix}$$

8. B

$$\begin{pmatrix} x \\ 3 \end{pmatrix} - 4 \begin{pmatrix} -1 \\ 5 \end{pmatrix} = \begin{pmatrix} 6 \\ y \end{pmatrix}$$

$$\begin{pmatrix} x \\ 3 \end{pmatrix} - \begin{pmatrix} -4 \\ 20 \end{pmatrix} = \begin{pmatrix} 6 \\ y \end{pmatrix}$$

$$x + 4 = 6 \qquad 3 - 20 = y$$

$$x = 2 \qquad y = -17$$

9. B

$$p \begin{pmatrix} 4 \\ -3 \end{pmatrix} + \begin{pmatrix} 3 \\ 7 \end{pmatrix} = \begin{pmatrix} p \\ 10 \end{pmatrix}$$

$$-3p + 7 = 10$$

$$3p = 7 - 10$$

$$p = -\frac{3}{3}$$

$$= -1$$

10. A

$$3(4 \ p) + q(5 \ 6) = (27 \ 24)$$

$$12 + 5q = 27 \qquad 3p + 6q = 24$$

$$5q = 15 \qquad 3p = 24 - 18$$

$$q = 3 \qquad p = 2$$

$$p + q = 2 + 3$$

$$= 5$$

11. B

$$3 \begin{pmatrix} m & -2 \\ 4 & -3 \end{pmatrix} - \frac{1}{2} \begin{pmatrix} -8 & 12 \\ n & -4 \end{pmatrix} = \begin{pmatrix} 10 & -12 \\ 8 & -7 \end{pmatrix}$$

$$3m - \frac{1}{2}(-8) = 10 \qquad 12 - \frac{1}{2}n = 8$$

$$3m + 4 = 10 \qquad \frac{1}{2}n = 4$$

$$3m = 6 \qquad n = 8$$

$$m = 2$$

12. A

$$\begin{pmatrix} 3 & -2 \\ 4 & 8 \end{pmatrix} - \begin{pmatrix} 1 & -6 \\ -2 & 2 \end{pmatrix} = 2 \begin{pmatrix} 1 & 2 \\ 3 & n \end{pmatrix}$$

$$8 - 2 = 2n$$

$$2n = 6$$

$$n = 3$$

13. B

$$\begin{pmatrix} 2 & 1 \\ 5 & 4 \end{pmatrix} \begin{pmatrix} -1 \\ 3 \end{pmatrix} = \begin{pmatrix} -2+3 \\ -5+12 \end{pmatrix}$$

$$= \begin{pmatrix} 1 \\ 7 \end{pmatrix}$$

14. C

$$\begin{pmatrix} -3 & 5 \\ 4 & -1 \end{pmatrix} \begin{pmatrix} 1 & 2 \\ 0 & 3 \end{pmatrix}$$

$$= \begin{pmatrix} -3+0 & -6+15 \\ 4+0 & 8-3 \end{pmatrix}$$

$$= \begin{pmatrix} -3 & 9 \\ 4 & 5 \end{pmatrix}$$

15. B

$$\begin{aligned} & (2 \ -2 \ 0) \begin{pmatrix} 4 & 2 \\ -2 & 0 \\ 3 & 5 \end{pmatrix} \\ &= (8 + 4 + 0 \quad 4 + 0 + 0) \\ &= (12 \ 4) \end{aligned}$$

16. A

$$\begin{aligned} & \left(4 \ \frac{1}{6}\right) \begin{pmatrix} 0 & -3 \\ 12 & 6 \end{pmatrix} = (0 + 2 \quad -12 + 1) \\ &= (2 \ -11) \end{aligned}$$

17. D

$$\begin{aligned} & (9 \ 3) \begin{pmatrix} x \\ -6 \end{pmatrix} = (27) \\ & 9x - 18 = 27 \\ & 9x = 45 \\ & x = 5 \end{aligned}$$

18. C

$$\begin{aligned} & (2p \ 5) \begin{pmatrix} 3 \\ -4 \end{pmatrix} = (16) \\ & 6p - 20 = 16 \\ & 6p = 36 \\ & p = 6 \end{aligned}$$

19. B

$$\begin{aligned} & \begin{pmatrix} -4 \\ 3 \end{pmatrix} (2x \ 5) = \begin{pmatrix} 24 & -20 \\ -18 & 15 \end{pmatrix} \\ & -4(2x) = 24 \\ & -8x = 24 \\ & x = -3 \end{aligned}$$

20. C

$$\begin{aligned} & \begin{pmatrix} 4 \\ -2 \end{pmatrix} \begin{pmatrix} -1 & 0 \\ 1 & 5 \end{pmatrix} \\ & \begin{matrix} 2 \times 1 & 2 \times 2 \\ \uparrow & \uparrow \\ \text{Tidak sama} \end{matrix} \end{aligned}$$

∴ Maka, pasangan matriks ini tidak boleh didarab.

21. D

$$\begin{aligned} & \begin{pmatrix} p & q \\ r & s \end{pmatrix}^{-1} = \frac{1}{ps - qr} \begin{pmatrix} s & -q \\ -r & p \end{pmatrix} \\ &= \frac{1}{2} \begin{pmatrix} -2 & 1 \\ 6 & -4 \end{pmatrix} \end{aligned}$$

$$\therefore p = -4, q = -1, r = -6, s = -2$$

22. A

$$\begin{pmatrix} 5 & 6 \\ 7 & 10 \end{pmatrix} \begin{pmatrix} 6.50 \\ 9 \end{pmatrix} = \begin{pmatrix} x \\ y \end{pmatrix}$$

Praktis Formatif: Kertas 2

$$\begin{aligned} 1. \text{ (a) } m \begin{pmatrix} 2 & -3 \\ n & 5 \end{pmatrix} &= \begin{pmatrix} 5 & 3 \\ -4 & 2 \end{pmatrix}^{-1} \\ &= \frac{1}{5(2) - 3(-4)} \begin{pmatrix} 2 & -3 \\ 4 & 5 \end{pmatrix} \\ &= \frac{1}{10 + 12} \begin{pmatrix} 2 & -3 \\ 4 & 5 \end{pmatrix} \\ &= \frac{1}{22} \begin{pmatrix} 2 & -3 \\ 4 & 5 \end{pmatrix} \end{aligned}$$

$$\therefore m = \frac{1}{22}, n = 4$$

$$\begin{aligned} \text{(b) } \begin{pmatrix} 5 & 3 \\ -4 & 2 \end{pmatrix} \begin{pmatrix} x \\ y \end{pmatrix} &= \begin{pmatrix} 26 \\ -12 \end{pmatrix} \\ \begin{pmatrix} x \\ y \end{pmatrix} &= \frac{1}{22} \begin{pmatrix} 2 & -3 \\ 4 & 5 \end{pmatrix} \begin{pmatrix} 26 \\ -12 \end{pmatrix} \\ &= \frac{1}{22} \begin{pmatrix} 2(26) + (-3)(-12) \\ 4(26) + 5(-12) \end{pmatrix} \\ &= \frac{1}{22} \begin{pmatrix} 88 \\ 44 \end{pmatrix} = \begin{pmatrix} 4 \\ 2 \end{pmatrix} \end{aligned}$$

$$\therefore x = 4, y = 2$$

$$\begin{aligned} 2. \text{ (a) } \mathbf{M} &= \begin{pmatrix} 4 & 2 \\ 5 & 3 \end{pmatrix}^{-1} \\ &= \frac{1}{4(3) - 2(5)} \begin{pmatrix} 3 & -2 \\ -5 & 4 \end{pmatrix} \\ &= \frac{1}{12 - 10} \begin{pmatrix} 3 & -2 \\ -5 & 4 \end{pmatrix} \\ &= \frac{1}{2} \begin{pmatrix} 3 & -2 \\ -5 & 4 \end{pmatrix} \text{ atau } \begin{pmatrix} \frac{3}{2} & -1 \\ -\frac{5}{2} & 2 \end{pmatrix} \end{aligned}$$

$$\begin{aligned} \text{(b) } \begin{pmatrix} 4 & 2 \\ 5 & 3 \end{pmatrix} \begin{pmatrix} x \\ y \end{pmatrix} &= \begin{pmatrix} 2 \\ 4 \end{pmatrix} \\ \begin{pmatrix} x \\ y \end{pmatrix} &= \frac{1}{2} \begin{pmatrix} 3 & -2 \\ -5 & 4 \end{pmatrix} \begin{pmatrix} 2 \\ 4 \end{pmatrix} \\ &= \frac{1}{2} \begin{pmatrix} 3(2) + (-2)(4) \\ -5(2) + 4(4) \end{pmatrix} \\ &= \frac{1}{2} \begin{pmatrix} -2 \\ 6 \end{pmatrix} \\ &= \begin{pmatrix} -1 \\ 3 \end{pmatrix} \end{aligned}$$

$$\therefore x = -1, y = 3$$

$$\begin{aligned} 3. \text{ (a) } \begin{pmatrix} 4 & -3 \\ 5 & -2 \end{pmatrix}^{-1} &= \frac{1}{4(-2) - (-3)(5)} \begin{pmatrix} -2 & 3 \\ -5 & 4 \end{pmatrix} \\ &= \frac{1}{-8 + 15} \begin{pmatrix} -2 & 3 \\ -5 & 4 \end{pmatrix} \\ &= \frac{1}{7} \begin{pmatrix} -2 & 3 \\ -5 & 4 \end{pmatrix} \text{ atau } \begin{pmatrix} -\frac{2}{7} & \frac{3}{7} \\ -\frac{5}{7} & \frac{4}{7} \end{pmatrix} \end{aligned}$$

$$\begin{aligned} \text{(b)} \quad \begin{pmatrix} 4 & -3 \\ 5 & -2 \end{pmatrix} \begin{pmatrix} x \\ y \end{pmatrix} &= \begin{pmatrix} 15 \\ 17 \end{pmatrix} \\ \begin{pmatrix} x \\ y \end{pmatrix} &= \frac{1}{7} \begin{pmatrix} -2 & 3 \\ -5 & 4 \end{pmatrix} \begin{pmatrix} 15 \\ 17 \end{pmatrix} \\ &= \frac{1}{7} \begin{pmatrix} -2(15) + 3(17) \\ -5(15) + 4(17) \end{pmatrix} \\ &= \frac{1}{7} \begin{pmatrix} 21 \\ -7 \end{pmatrix} \\ &= \begin{pmatrix} 3 \\ -1 \end{pmatrix} \end{aligned}$$

$$\therefore x = 3, y = -1$$

$$\begin{aligned} \text{4. (a)} \quad \begin{pmatrix} 4 & 6 \\ 3 & 5 \end{pmatrix}^{-1} &= \frac{1}{4(5) - 6(3)} \begin{pmatrix} 5 & -6 \\ -3 & 4 \end{pmatrix} \\ &= \frac{1}{20 - 18} \begin{pmatrix} 5 & -6 \\ -3 & 4 \end{pmatrix} \\ &= \frac{1}{2} \begin{pmatrix} 5 & -6 \\ -3 & 4 \end{pmatrix} \text{ atau } \begin{pmatrix} \frac{5}{2} & -3 \\ -\frac{3}{2} & 2 \end{pmatrix} \end{aligned}$$

(b) Katakan RMx ialah harga sebiji betik dan RMy ialah harga sebiji jambu batu.

$$\begin{aligned} 4x + 6y &= 38 \\ 3x + 5y &= 30 \\ \begin{pmatrix} 4 & 6 \\ 3 & 5 \end{pmatrix} \begin{pmatrix} x \\ y \end{pmatrix} &= \begin{pmatrix} 38 \\ 30 \end{pmatrix} \\ \begin{pmatrix} x \\ y \end{pmatrix} &= \frac{1}{2} \begin{pmatrix} 5 & -6 \\ -3 & 4 \end{pmatrix} \begin{pmatrix} 38 \\ 30 \end{pmatrix} \\ &= \frac{1}{2} \begin{pmatrix} 5(38) - 6(30) \\ -3(38) + 4(30) \end{pmatrix} \\ &= \frac{1}{2} \begin{pmatrix} 10 \\ 6 \end{pmatrix} \\ &= \begin{pmatrix} 5 \\ 3 \end{pmatrix} \end{aligned}$$

\therefore Sebiji betik berharga RM5 dan sebiji jambu batu berharga RM3.

$$\begin{aligned} \text{5. (a)} \quad x + y &= 9 \\ 6x + 4y &= 44 \end{aligned}$$

$$\begin{aligned} \text{(b)} \quad \begin{pmatrix} 1 & 1 \\ 6 & 4 \end{pmatrix} \begin{pmatrix} x \\ y \end{pmatrix} &= \begin{pmatrix} 9 \\ 44 \end{pmatrix} \\ \frac{1}{4 - 6} \begin{pmatrix} 4 & -1 \\ -6 & 1 \end{pmatrix} \begin{pmatrix} x \\ y \end{pmatrix} &= \begin{pmatrix} -2 & \frac{1}{2} \\ 3 & -\frac{1}{2} \end{pmatrix} \begin{pmatrix} 9 \\ 44 \end{pmatrix} \\ \begin{pmatrix} x \\ y \end{pmatrix} &= \begin{pmatrix} -18 + 22 \\ 27 - 22 \end{pmatrix} \\ \begin{pmatrix} x \\ y \end{pmatrix} &= \begin{pmatrix} 4 \\ 5 \end{pmatrix} \end{aligned}$$

$$\therefore x = 4, y = 5$$

6. Katakan RMx ialah harga bagi satu kupon makanan dan RMy ialah harga bagi satu kupon minuman.

$$3x + 4y = 27$$

$$2x + 5y = 25$$

$$\begin{aligned} \begin{pmatrix} 3 & 4 \\ 2 & 5 \end{pmatrix} \begin{pmatrix} x \\ y \end{pmatrix} &= \begin{pmatrix} 27 \\ 25 \end{pmatrix} \\ \frac{1}{15 - 8} \begin{pmatrix} 5 & -4 \\ -2 & 3 \end{pmatrix} \begin{pmatrix} x \\ y \end{pmatrix} &= \frac{1}{7} \begin{pmatrix} 5 & -4 \\ -2 & 3 \end{pmatrix} \begin{pmatrix} 27 \\ 25 \end{pmatrix} \\ \begin{pmatrix} 1 & 0 \\ 0 & 1 \end{pmatrix} \begin{pmatrix} x \\ y \end{pmatrix} &= \frac{1}{7} \begin{pmatrix} 5 & -4 \\ -2 & 3 \end{pmatrix} \begin{pmatrix} 27 \\ 25 \end{pmatrix} \\ \begin{pmatrix} x \\ y \end{pmatrix} &= \begin{pmatrix} \frac{135}{7} - \frac{100}{7} \\ -\frac{54}{7} + \frac{75}{7} \end{pmatrix} \\ &= \begin{pmatrix} 5 \\ 3 \end{pmatrix} \end{aligned}$$

\therefore Harga bagi satu kupon makanan = RM5
 Harga bagi satu kupon minuman = RM3

7. Katakan bilangan kanak-kanak = x dan bilangan orang dewasa = y dalam kumpulan itu.

$$x + y = 50$$

$$10x + 30y = 600$$

$$\begin{pmatrix} 1 & 1 \\ 10 & 30 \end{pmatrix} \begin{pmatrix} x \\ y \end{pmatrix} = \begin{pmatrix} 50 \\ 600 \end{pmatrix}$$

$$\begin{aligned} \begin{pmatrix} x \\ y \end{pmatrix} &= \frac{1}{1(30) - 1(10)} \begin{pmatrix} 30 & -1 \\ -10 & 1 \end{pmatrix} \begin{pmatrix} 50 \\ 600 \end{pmatrix} \\ &= \frac{1}{20} \begin{pmatrix} 30(50) + (-1)(600) \\ -10(50) + 1(600) \end{pmatrix} \\ &= \frac{1}{20} \begin{pmatrix} 900 \\ 100 \end{pmatrix} \\ &= \begin{pmatrix} 45 \\ 5 \end{pmatrix} \end{aligned}$$

Maka, bilangan kanak-kanak ialah 45 orang dan bilangan orang dewasa ialah 5 orang.

FOKUS KBAT

$$\text{(a)} \quad x + y = 12$$

$$7x + 4y = 72$$

$$\text{(b)} \quad \begin{pmatrix} 1 & 1 \\ 7 & 4 \end{pmatrix} \begin{pmatrix} x \\ y \end{pmatrix} = \begin{pmatrix} 12 \\ 72 \end{pmatrix}$$

$$\begin{aligned} \frac{1}{4 - 7} \begin{pmatrix} 4 & -1 \\ -7 & 1 \end{pmatrix} \begin{pmatrix} x \\ y \end{pmatrix} &= \begin{pmatrix} -\frac{4}{3} & \frac{1}{3} \\ \frac{7}{3} & -\frac{1}{3} \end{pmatrix} \begin{pmatrix} 12 \\ 72 \end{pmatrix} \\ \begin{pmatrix} x \\ y \end{pmatrix} &= \begin{pmatrix} -16 + 24 \\ 28 - 24 \end{pmatrix} \\ \begin{pmatrix} x \\ y \end{pmatrix} &= \begin{pmatrix} 8 \\ 4 \end{pmatrix} \end{aligned}$$

$$\therefore x = 8, y = 4$$

JAWAPAN

BAB 5: UBAHAN

5.1

A

1.

x	2	4	6	8
y	6	12	15	20
$\frac{y}{x^2}$	$\frac{6}{2^2} = \frac{3}{2}$	$\frac{12}{4^2} = \frac{3}{4}$	$\frac{15}{6^2} = \frac{5}{12}$	$\frac{20}{8^2} = \frac{5}{16}$

y tidak berubah secara langsung dengan x^2 .
y does not vary directly as x^2 .

2.

x	1	2	3	4
y	3	24	81	192
$\frac{y}{x^3}$	$\frac{3}{1^3} = 3$	$\frac{24}{2^3} = 3$	$\frac{81}{3^3} = 3$	$\frac{192}{4^3} = 3$

y berubah secara langsung dengan x^3 .
y varies directly as x^3 .

3.

x	9	16	25	36
y	6	8	10	12
$\frac{y}{\sqrt{x}}$	$\frac{6}{\sqrt{9}} = 2$	$\frac{8}{\sqrt{16}} = 2$	$\frac{10}{\sqrt{25}} = 2$	$\frac{12}{\sqrt{36}} = 2$

y berubah secara langsung dengan \sqrt{x} .
y varies directly as \sqrt{x} .

B

- (i) $y \propto x$
(ii) $y = kx$
- (i) $A \propto l^2$
(ii) $A = kl^2$
- (i) $V \propto r^3$
(ii) $V = kr^3$
- (i) $E \propto \sqrt{F}$
(ii) $E = k\sqrt{F}$
- (i) $F \propto \sqrt{G}$
(ii) $F = k\sqrt{G}$

C

- (a) $y = kx$
 $36 = k(8)$
 $k = \frac{9}{2}$
 $\therefore y = \frac{9}{2}x$

$$(b) y = \frac{9}{2}(12)$$

$$= 54$$

- (a) $p = kq$
 $4 = k\left(\frac{1}{6}\right)$
 $k = 24$
 $\therefore p = 24q$
(b) $12 = 24q$
 $q = \frac{12}{24}$
 $= \frac{1}{2}$

- (a) $18 = k(64)^{\frac{1}{2}}$
 $18 = 8k$
 $k = \frac{9}{4}$
 $\therefore y = \frac{9}{4}(x - 5)^{\frac{1}{2}}$
(b) $y = \frac{9}{4}(149 - 5)^{\frac{1}{2}}$
 $= \frac{9}{4} \times 12$
 $= 27$

- (a) $P = kQ^3$
 $128 = k(8)^3$
 $k = \frac{128}{8^3}$
 $= \frac{1}{4}$
 $\therefore P = \frac{1}{4}Q^3$
(b) $6.75 = \frac{1}{4}Q^3$
 $Q^3 = 27$
 $Q = \sqrt[3]{27}$
 $= 3$

- (a) $y = kx^2$
 $\frac{4}{5} = k\left(\frac{1}{9}\right)$
 $k = \frac{36}{5}$
 $\therefore y = \frac{36}{5}x^2$
(b) $p = \frac{36}{5} \times 5^2$
 $= 180$

6. (a) $V = k\sqrt{W}$
 $26 = k\sqrt{169}$
 $k = 2$
 $\therefore V = 2\sqrt{W}$
 (b) $m = 2 \times \sqrt{81}$
 $= 2 \times 9$
 $= 18$

D

(a) $A \propto r^2$
 $A = kr^2$
 $44.1 = k \times 10.5^2$
 $k = \frac{44.1}{10.5^2}$
 $= 0.4$
 $\therefore A = 0.4r^2$
 (b) $A = 0.4 \times 21^2$
 $= 176.4 \text{ cm}^2$

5.2

A

1.

x	1	2	3	4
y	16	8	4	2
x^2y	$1^2(16)$ $= 16$	$2^2(8)$ $= 32$	$3^2(4)$ $= 36$	$4^2(2)$ $= 32$

y tidak berubah secara songsang dengan x^2 .
 y does not vary inversely as x^2 .

2.

x	1	2	3	4
y	27	3	2	1
x^3y	$1^3(27)$ $= 27$	$2^3(3)$ $= 24$	$3^3(2)$ $= 54$	$4^3(1)$ $= 64$

y tidak berubah secara songsang dengan x^3 .
 y does not vary inversely as x^3 .

3.

x	4	9	16	25
y	30	20	15	12
$\sqrt{x}y$	$\sqrt{4}(30)$ $= 60$	$\sqrt{9}(20)$ $= 60$	$\sqrt{16}(15)$ $= 60$	$\sqrt{25}(12)$ $= 60$

y berubah secara songsang dengan \sqrt{x} .
 y varies inversely as \sqrt{x} .

B

1. (i) $s \propto \frac{1}{v}$ (ii) $s = \frac{k}{v}$
 2. (i) $M \propto \frac{1}{N^3}$ (ii) $M = \frac{k}{N^3}$
 3. (i) $L \propto \frac{1}{j^2}$ (ii) $L = \frac{k}{j^2}$

4. (i) $y \propto \frac{1}{\sqrt{x}}$ (ii) $y = \frac{k}{\sqrt{x}}$
 5. (i) $w \propto \frac{1}{\ell^3}$ (ii) $w = \frac{k}{\ell^3}$

C

1. (a) $y = \frac{k}{x}$
 $\frac{1}{2} = \frac{k}{8}$
 $k = 4$
 $\therefore y = \frac{4}{x}$
 (b) $5 = \frac{4}{x}$
 $x = \frac{4}{5}$

2. (a) $k = pr = 27$
 $\therefore p = \frac{27}{r}$
 $= \frac{27}{9}$
 $= 3$
 (b) $\frac{1}{3} = \frac{27}{r}$
 $r = 27 \times 3$
 $= 81$

3. (a) $y = \frac{k}{x^3}$
 $\frac{3}{4} = \frac{k}{4^3}$
 $k = \frac{3}{4} \times 64$
 $= 48$
 $\therefore y = \frac{48}{x^3}$

(b) $y = \frac{48}{6^3}$
 $= \frac{48}{216}$
 $= \frac{2}{9}$

4. (a) $m = \frac{k}{\sqrt{n}}$
 $5 = \frac{k}{\sqrt{2\,500}}$
 $k = 5 \times 50$
 $= 250$
 $\therefore m = \frac{250}{\sqrt{n}}$

$$(b) 10 = \frac{250}{\sqrt{n}}$$

$$\sqrt{n} = \frac{250}{10}$$

$$= 25$$

$$n = 25^2$$

$$= 625$$

$$5. (a) t = \frac{k}{w^2}$$

$$3 = \frac{k}{2^2}$$

$$k = 3 \times 4$$

$$= 12$$

$$\therefore t = \frac{12}{w^2}$$

$$(b) 75 = \frac{12}{r^2}$$

$$r^2 = \frac{12}{75}$$

$$= \frac{4}{25}$$

$$r = \sqrt{\frac{4}{25}}$$

$$= \frac{2}{5} \text{ atau } 0.4$$

$$6. 4 = \frac{k}{2^3}$$

$$k = 4 \times 8$$

$$= 32$$

$$y = \frac{32}{x^3}$$

$$p = \frac{32}{3^3}$$

$$= \frac{32}{27}$$

$$= 1\frac{5}{27}$$

D

$$t \propto \frac{1}{p^2}$$

$$t = \frac{k}{p^2}$$

$$6 = \frac{k}{4.5^2}$$

$$k = 121.5$$

$$\therefore t = \frac{121.5}{p^2}$$

$$t = \frac{121.5}{3^2}$$

$$= 13.5 \text{ cm}$$

5.3

A

1. (i) $w \propto xy$
(ii) $w = kxy$
2. (i) $Z \propto \frac{1}{X\sqrt{Y}}$
(ii) $Z = \frac{k}{X\sqrt{Y}}$
3. (i) $e \propto \frac{f}{g}$
(ii) $e = \frac{kf}{g}$
4. (i) $s \propto \frac{t^2}{u}$
(ii) $s = \frac{kt^2}{u}$
5. (i) $y \propto vw^{\frac{1}{2}}$
(ii) $y = kvw^{\frac{1}{2}}$
6. (i) $P \propto \frac{Q}{R^2}$
(ii) $P = \frac{kQ}{R^2}$
7. (i) $x \propto \frac{1}{z\sqrt{y}}$
(ii) $x = \frac{k}{z\sqrt{y}}$
8. (i) $t \propto \frac{u^3}{\sqrt{v}}$
(ii) $t = \frac{ku^3}{\sqrt{v}}$
9. (i) $p \propto qr^3$
(ii) $p = kqr^3$
10. (i) $f \propto \frac{\sqrt{g}}{h^3}$
(ii) $f = \frac{k\sqrt{g}}{h^3}$

B

$$1. (a) L = \frac{k}{M\sqrt{p}}$$

$$\frac{1}{2} = \frac{k}{3\sqrt{64}}$$

$$k = \frac{1}{2} \times 24$$

$$= 12$$

$$\therefore L = \frac{12}{M\sqrt{p}}$$

$$(b) L = \frac{12}{3\sqrt{49}}$$

$$= \frac{4}{7}$$

$$2. (a) w = \frac{kx^2}{y}$$

$$15 = \frac{k(3^2)}{9}$$

$$k = 15$$

$$\therefore w = \frac{15x^2}{y}$$

$$(b) 12 = \frac{15(4^2)}{m}$$

$$m = \frac{240}{12}$$

$$= 20$$

$$3. (a) f = \frac{kg^3}{\sqrt{h}}$$

$$24 = \frac{k(2^3)}{\sqrt{36}}$$

$$k = 24 \times \frac{6}{8}$$

$$= 18$$

$$\therefore f = \frac{18g^3}{\sqrt{h}}$$

$$(b) 162 = \frac{18g^3}{\sqrt{9}}$$

$$g^3 = 162 \times \frac{3}{18}$$

$$= 27$$

$$g = \sqrt[3]{27}$$

$$= 3$$

D

$$(a) t \propto \frac{A}{p}$$

$$t = \frac{kA}{p}$$

$$4 = \frac{360k}{8}$$

$$k = \frac{4}{45}$$

$$\therefore t = \frac{4A}{45p}$$

$$(b) 5 = \frac{4 \times 675}{45p}$$

$$p = 12$$

Praktis Formatif: Kertas 1**1. C**

$$g \propto f^3$$

2. D

$$w \propto p^3$$

$$w = kp^3$$

$$12 = k(3)^3$$

$$k = \frac{12}{27}$$

$$= \frac{4}{9}$$

$$w = \frac{4}{9}p^3$$

$$96 = \frac{4}{9}p^3$$

$$p^3 = 216$$

$$p = \sqrt[3]{216}$$

$$= 6$$

3. A

$$Q \propto \sqrt{P}$$

$$Q = k\sqrt{P}$$

$$4 = k\sqrt{\frac{1}{9}}$$

$$k = 12$$

$$Q = 12\sqrt{P}$$

$$3 = 12\sqrt{m}$$

$$\sqrt{m} = \frac{3}{12}$$

$$= \frac{1}{4}$$

$$m = \left(\frac{1}{4}\right)^2$$

$$= \frac{1}{16}$$

4. B

$$I \propto j^3$$

$$I = kj^3$$

$$k = \frac{I}{j^3}$$

5. D

x	1	2	3	4	5
y	2	16	54	128	250
$\frac{y}{x^3}$	$\frac{2}{1^3} = 2$	$\frac{16}{2^3} = 2$	$\frac{54}{3^3} = 2$	$\frac{128}{4^3} = 2$	$\frac{250}{5^3} = 2$

$$\therefore y = 2x^3$$

6. D

$$V \propto \frac{1}{W^2}$$

$$V = \frac{k}{W^2}$$

7. C

$$t \propto \frac{1}{\sqrt{s}}$$

$$t \propto \frac{k}{\sqrt{s}}$$

$$k = 2 \times \sqrt{100}$$

$$= 20$$

$$\therefore t = \frac{20}{\sqrt{s}}$$

8. B

$$y \propto \frac{1}{x}$$

$$y = \frac{k}{x}$$

$$8 = \frac{k}{5}$$

$$k = 40$$

$$y = \frac{40}{x}$$

$$n = \frac{40}{16}$$

$$= 2.5$$

9. A

$$p \propto \frac{1}{\sqrt[3]{q}}$$

$$p = \frac{k}{\sqrt[3]{q}}$$

$$k = 4 \times \sqrt[3]{\frac{1}{125}}$$

$$= 4 \times \frac{1}{5}$$

$$= \frac{4}{5}$$

$$p = \frac{4}{5 \times \sqrt[3]{q}}$$

$$= \frac{4}{5 \times \sqrt[3]{512}}$$

$$= \frac{4}{5 \times 8}$$

$$= \frac{4}{40}$$

$$= \frac{1}{10}$$

10. C

$$t \propto \frac{1}{y}$$

$$t = \frac{k}{y}$$

$$165 = \frac{k}{9}$$

$$= 1485$$

$$t = \frac{1485}{y}$$

$$= \frac{1485}{15}$$

$$= 99$$

11. D

$$y \propto \frac{1}{3x - 2}$$

$$y = \frac{k}{3x - 2}$$

$$2 = \frac{k}{3(3) - 2}$$

$$k = 2 \times 7$$

$$= 14$$

$$y = \frac{14}{3x - 2}$$

$$-1 = \frac{14}{3x - 2}$$

$$3x - 2 = -12$$

$$x = -4$$

12. D

$$p \propto \frac{q^3}{\sqrt{r}} \Rightarrow p \propto \frac{q^3}{r^{\frac{1}{2}}}$$

$$\therefore v = 3, w = \frac{1}{2}$$

13. A

$$p = \frac{kq^{\frac{1}{2}}}{r^3}$$

$$3 = \frac{k(144)^{\frac{1}{2}}}{2^3}$$

$$k = 2$$

$$p = \frac{2q^{\frac{1}{2}}}{r^3}$$

$$= \frac{2(36)^{\frac{1}{2}}}{4^3}$$

$$= \frac{3}{16}$$

14. B

$$\frac{yz^2}{x} = 8$$

$$y = \frac{8x}{z^2}$$

$\therefore y$ berubah secara langsung dengan x dan secara songsang dengan kuasa dua z .

15. B

$$P \propto \frac{Q}{\sqrt{R}}$$

$$P = \frac{kQ}{\sqrt{R}}$$

$$k = \frac{k(5)}{\sqrt{9}}$$

$$= \frac{18}{5}$$

$$P = \frac{18Q}{5\sqrt{R}}$$

$$k = \frac{18\left(\frac{5}{3}\right)}{5\sqrt{m}}$$

$$\sqrt{m} = \frac{1}{2}$$

$$m = \left(\frac{1}{2}\right)^2$$

$$= \frac{1}{4}$$

FOKUS KBAT

$$N \propto \frac{A}{P}$$

$$N = \frac{kA}{P}$$

$$12\,000 = \frac{k \times 72\,000}{270}$$

$$k = \frac{12\,000 \times 270}{72\,000}$$

$$= 45$$

$$N = \frac{45 \times 150\,000}{270}$$

$$= 25\,000$$

Maka, bilangan kasut yang dijual ialah 25 000 pasang.
(A)

JAWAPAN

BAB 6: KECERUNAN DAN LUAS DI BAWAH GRAF

6.1

A

- Laju = $\frac{30 - 0}{3 - 0}$
= 10 m s^{-1}
 - Tempoh masa = $7 - 3$
= 4 s
 - Laju = $\frac{45 - 30}{10 - 7}$
= $\frac{15}{3}$
= 5 m s^{-1}
- Laju = $\frac{200 - 40}{8 - 0}$
= $\frac{160}{8}$
= 20 m s^{-1}
 - Laju = $\frac{0 - 200}{12 - 8}$
= $\frac{-200}{4}$
= -50 m s^{-1}
 \therefore Laju = 50 m s^{-1}
 - Laju purata = $\frac{160 + 200}{12}$
= $\frac{360}{12}$
= 30 m s^{-1}
- Tempoh masa = $40 - 20 = 20$ minit
 - Jarak = $75 - 15 = 60$ km
 - Laju purata = $\frac{75}{80} = 75 \times \frac{60}{80}$
= $56\frac{1}{4} \text{ km j}^{-1}$ atau 56.25 km j^{-1}

B

- Kadar perubahan laju = $\frac{12 - 0}{4 - 0}$
= $\frac{12}{4}$
= 3 m s^{-2}
 - Kadar perubahan laju = $\frac{20 - 12}{20 - 4}$
= $\frac{8}{16}$
= $\frac{1}{2} \text{ m s}^{-2}$
atau 0.5 m s^{-2}

$$2. (a) \text{ Kadar perubahan laju} = \frac{21 - 5}{3 - 0}$$

$$= \frac{16}{3}$$

$$= 5\frac{1}{3} \text{ m s}^{-2}$$

atau 5.33 m s^{-2}

$$(b) \text{ Tempoh masa} = 7 - 3$$

$$= 4 \text{ s}$$

$$(c) \frac{0 - 21}{t - 7} = -7$$

$$t - 7 = \frac{-21}{-7}$$

$$= 3$$

$$t = 10$$

$$3. (a) \frac{v - 5}{6} = 4$$

$$v = 4(6) + 5$$

$$= 29$$

$$(b) \text{ Kadar perubahan laju} = \frac{0 - 29}{10 - 6}$$

$$= -\frac{29}{4}$$

$$= -7\frac{1}{4} \text{ m s}^{-2}$$

atau -7.25 m s^{-2}

6.2

A

- Luas = $\frac{1}{2}[(10 - 4) + 14] \times 12$
= $\frac{1}{2}(6 + 14) \times 12$
= 120 unit^2
- Luas = $\left(\frac{1}{2} \times 8 \times 15\right) + [(20 - 8) \times 15]$
= $60 + 180$
= 240 unit^2
- Luas = $\left[\frac{1}{2}(12 + 20) \times 5\right] + (10 \times 12)$
= $80 + 120$
= 200 unit^2
- Luas = $\left[\frac{1}{2}(4 + 10) \times 5\right] + (7 \times 10) + \left(\frac{1}{2} \times 8 \times 10\right)$
= $35 + 70 + 40$
= 145 unit^2

$$\begin{aligned}
 5. \text{ Luas} &= \left[\frac{1}{2}(6 + 15) \times 4 \right] + \left[\frac{1}{2}(10 + 15) \times 4 \right] + \\
 &\quad (7 \times 10) \\
 &= 42 + 50 + 70 \\
 &= 162 \text{ unit}^2
 \end{aligned}$$

B

$$\begin{aligned}
 1. \text{ Jarak} &= \left[\frac{1}{2}(8 + 15) \times 7 \right] + \left(\frac{1}{2} \times 10 \times 15 \right) \\
 &= 80.5 + 75 \\
 &= 155.5 \text{ m}
 \end{aligned}$$

$$\begin{aligned}
 2. \text{ Jarak} &= (12 \times 8) + \left[\frac{1}{2}(8 + 12) \times 8 \right] \\
 &= 96 + 80 \\
 &= 176 \text{ m}
 \end{aligned}$$

$$\begin{aligned}
 3. \text{ Jarak} &= \left[\frac{1}{2}(9 + 18) \times 6 \right] + \left[\frac{1}{2}(9 + 15) \times 2 \right] \\
 &\quad + (10 \times 15) \\
 &= 81 + 24 + 150 \\
 &= 255 \text{ m}
 \end{aligned}$$

$$\begin{aligned}
 4. \text{ Jarak} &= (4 \times 40) + \left[\frac{1}{2}(40 + 60) \times 6 \right] + \\
 &\quad \left(\frac{1}{2} \times 6 \times 60 \right) \\
 &= 160 + 300 + 180 \\
 &= 640 \text{ m}
 \end{aligned}$$

$$\begin{aligned}
 5. \text{ Jarak} &= \left[\frac{1}{2}(8 + 18) \times 4 \right] + \left[\frac{1}{2}(8 + 12) \times 4 \right] \\
 &\quad + (8 \times 12) + \left(\frac{1}{2} \times 4 \times 12 \right) \\
 &= 52 + 40 + 96 + 24 \\
 &= 212 \text{ m}
 \end{aligned}$$

C

$$\begin{aligned}
 1. (a) \frac{20 - u}{3} &= 3 \\
 20 - u &= 9 \\
 u &= 20 - 9 \\
 &= 11
 \end{aligned}$$

$$\begin{aligned}
 (b) \text{ Jumlah jarak yang dilalui} \\
 &= \left[\frac{1}{2}(11 + 20) \times 3 \right] + (5 \times 20) + \left(\frac{1}{2} \times 4 \times 20 \right) \\
 &= 46.5 + 100 + 40 \\
 &= 186.5 \text{ m}
 \end{aligned}$$

$$\begin{aligned}
 (c) \text{ Kadar perubahan laju} &= \frac{0 - 20}{12 - 8} \\
 &= \frac{-20}{4} \\
 &= -5 \text{ m s}^{-2}
 \end{aligned}$$

$$\begin{aligned}
 2. (a) \frac{8 - 0}{t} &= 2 \\
 t &= \frac{8}{2} \\
 &= 4
 \end{aligned}$$

$$\begin{aligned}
 (b) \text{ Jarak} &= (6 - 4) \times 8 \\
 &= 16 \text{ m}
 \end{aligned}$$

$$\begin{aligned}
 (c) \text{ Jumlah jarak yang dilalui} \\
 &= \left(\frac{1}{2} \times 4 \times 8 \right) + 16 + \left[\frac{1}{2}(8 + 18) \times 6 \right] \\
 &= 16 + 16 + 78 \\
 &= 110 \text{ m}
 \end{aligned}$$

$$3. (a) 16 \text{ m s}^{-1}$$

$$\begin{aligned}
 (b) \left[\frac{1}{2}(16 + 24) \times t \right] + [(12 - t) \times 16] &= 232 \\
 20t + 192 - 16t &= 232 \\
 4t &= 40 \\
 t &= 10
 \end{aligned}$$

$$\begin{aligned}
 (c) \text{ Kadar perubahan laju} \\
 &= \frac{0 - 16}{20 - 12} \\
 &= \frac{-16}{8} \\
 &= -2 \text{ m s}^{-2}
 \end{aligned}$$

$$\begin{aligned}
 4. (a) \frac{1}{2}(10 + v) \times 6 &= 78 \\
 3(10 + v) &= 78 \\
 10 + v &= 26 \\
 v &= 16
 \end{aligned}$$

$$\begin{aligned}
 (b) \text{ Kadar perubahan laju} &= \frac{10 - 16}{6} \\
 &= \frac{-6}{6} \\
 &= -1 \text{ m s}^{-2}
 \end{aligned}$$

$$\begin{aligned}
 (c) 78 + \left[\frac{1}{2}(10 + 14)(t - 6) \right] + \left[\frac{1}{2}(18 - t) \times 14 \right] \\
 &= 182 \\
 78 + 12t - 72 + 126 - 7t &= 182 \\
 5t + 132 &= 182 \\
 5t &= 50 \\
 t &= 10
 \end{aligned}$$

$$\begin{aligned}
 5. (a) \text{ Kadar perubahan laju} &= \frac{18 - 5}{3} \\
 &= \frac{13}{3} \\
 &= 4\frac{1}{3} \text{ m s}^{-2} \\
 &\text{atau } 4.33 \text{ m s}^{-2}
 \end{aligned}$$

$$\begin{aligned}
 (b) \left[\frac{1}{2}(u + 18) \times 4 \right] + (8 \times u) &= 156 \\
 2u + 36 + 8u &= 156 \\
 10u + 36 &= 156 \\
 10u &= 120 \\
 u &= 12
 \end{aligned}$$

$$\begin{aligned}
 \text{(c) Jumlah jarak} &= \left[\frac{1}{2}(5 + 18) \times 3 \right] + 156 \\
 &= 34.5 + 156 \\
 &= 190.5 \text{ m} \\
 \therefore \text{Laju purata} &= \frac{190.5}{15} \\
 &= 12.7 \text{ m s}^{-1}
 \end{aligned}$$

Praktis Formatif: Kertas 2

- 16 m s⁻¹
 - Kadar perubahan laju = $\frac{0 - 16}{4} = -4 \text{ m s}^{-2}$
 - $\frac{1}{2} \times t \times 20 = \frac{1}{2}(8 + 12) \times 16$
10t = 160
t = 16
- Laju = $\frac{160 - 120}{1} = 40 \text{ km j}^{-1}$
 - Jam 0930,
120 km dari bandar L atau 40 km dari bandar K
 - Jarak = 140 - 40 = 100 km

- (i), (ii)

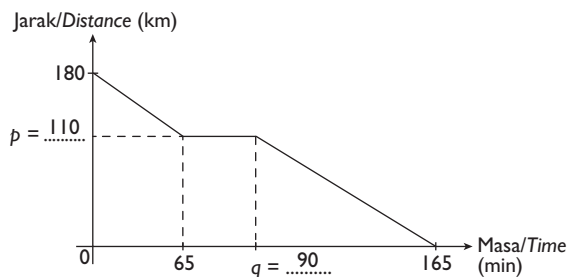

$$\begin{aligned}
 p &= 180 - 70 = 110 \\
 \text{Tempoh masa dari jam 1000 hingga jam 1130} \\
 &= 1 \text{ jam } 30 \text{ minit} \\
 &= 90 \text{ minit} \\
 \therefore q &= 90
 \end{aligned}$$

- Jumlah jarak = 180 km
Jumlah masa = 2 jam 45 minit = 2.75 jam
Laju purata = $\frac{180 \text{ km}}{2.75 \text{ j}} = 65.45 \text{ km j}^{-1}$
- 30 - 12 = 18 s
 - Kadar perubahan laju = $\frac{0 - 18}{12} = -1\frac{1}{2} \text{ m s}^{-2}$ atau -1.5 m s^{-2}

$$\begin{aligned}
 \text{(c) } \left[\frac{1}{2}(u + 18) \times 12 \right] + 18 \times 18 + \left[\frac{1}{2}(42 - 30) \times 18 \right] \\
 = 582 \\
 6u + 108 + 324 + 108 = 582 \\
 6u + 540 = 582 \\
 6u = 582 - 540 \\
 = 42 \\
 u = 7
 \end{aligned}$$

- 360 cm s⁻¹
 - Kadar perubahan laju = $\frac{360}{6} = 60 \text{ cm s}^{-2}$
 - $\frac{1}{2} \times 6 \times 360 = \frac{1}{2} \times \left[\frac{1}{2}(360 + 600) \times (t - 8) \right]$
1 080 = 240 × (t - 8)
 $t - 8 = \frac{1\ 080}{240} = 4.5$
t = 12.5
- Kesha
 - Tempoh masa = 36 - 18 = 18 s
 - Jarak Jasmine = 200 - 140 = 60 m
 - Laju purata = $\frac{200}{40} = 5 \text{ m s}^{-1}$

FOKUS KBAT

- Laju = $\frac{80}{1.25} = 64 \text{ km j}^{-1}$
 -

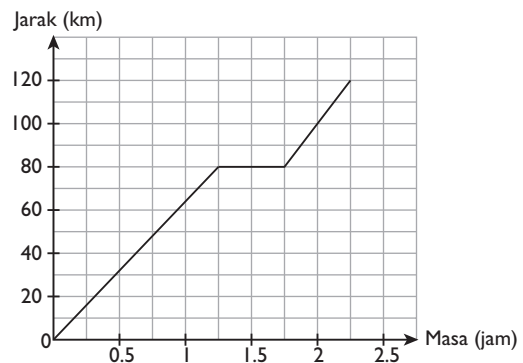

- Masa diambil untuk keseluruhan perjalanan = 2.25 jam = 2 jam 15 minit
Masa ketibaan = 2:45 p.m. + 2 jam 15 minit = 5:00 p.m.
- Laju purata = $\frac{120}{2.25} = 53\frac{1}{3} \text{ km j}^{-1}$ atau 53.33 km j^{-1}

JAWAPAN

BAB 7: KEBARANGKALIAN II

7.1

A

- $S = \{90, 91, 92, 93, 94, 95, 96, 97\}$
 $n(S) = 8$
Katakan A = Peristiwa satu nombor perdana dipilih
 $A = \{97\}$
 $n(A) = 1$
 $P(A) = \frac{1}{8}$
- $S = \{K, E, B, A, N, G, S, A, A, N\}$
 $n(S) = 10$
Katakan X = Peristiwa mendapat huruf A
 $n(X) = 3$
 $P(X) = \frac{3}{10}$
- $S = \{R_1, R_2, R_3, R_4, R_5, G_1, G_2, G_3, G_4, Y_1, Y_2, Y_3, Y_4, Y_5, Y_6\}$
 $n(S) = 15$
Katakan G = Peristiwa mendapat bola berwarna merah
 $n(G) = 5$
 $P(G) = \frac{5}{15}$
 $= \frac{1}{3}$

B

- $n(S) = 15$
Bilangan murid perempuan = $15 - 8$
 $= 7$
 $P(\text{perempuan}) = \frac{7}{15}$
- Bilangan murid lelaki = $75 - 20 - 15$
 $= 40$
 $n(S) = 75 - 15$
 $= 60$
 $P(\text{lelaki}) = \frac{40}{60}$
 $= \frac{2}{3}$
- $\frac{x}{12 + 8 + x} = \frac{1}{6}$
 $\frac{x}{20 + x} = \frac{1}{6}$
 $6x = 20 + x$
 $5x = 20$
 $x = 4$
Bilangan bola kuning = 4

$$4. \text{ Bilangan murid Cina} = \frac{2}{5} \times 40$$
$$= 16$$

$$\text{Bilangan murid Iban} = 40 - 18 - 16$$
$$= 6$$

$$P(\text{Iban}) = \frac{6}{40}$$
$$= \frac{3}{20}$$

7.2

$$1. P(\text{Cip hijau}) = 1 - \frac{1}{3} - \frac{2}{5}$$
$$= \frac{4}{15}$$

$$\text{Bilangan cip hijau} = \frac{4}{15} \times 90$$
$$= 24$$

$$2. P(\text{Guli putih}) = 1 - \frac{2}{3} - \frac{1}{5}$$
$$= \frac{2}{15}$$

$$\text{Jumlah bilangan guli} = 6 \times \frac{15}{2}$$
$$= 45$$

$$3. P(\text{Gagal}) = 1 - \frac{7}{20}$$
$$= \frac{13}{20}$$

$$\text{Bilangan kali Peter gagal menjaringkan gol}$$
$$= \frac{13}{20} \times 60$$
$$= 39$$

$$4. P(\text{Epal yang tidak rosak}) = 1 - \frac{2}{5}$$
$$= \frac{3}{5}$$

$$\text{Bilangan epal yang tidak rosak}$$
$$= \frac{3}{5} \times 120$$
$$= 72$$

7.3

$$1. S = \{(3, A), (3, B), (3, D), (3, E), (4, A), (4, B), (4, D), (4, E), (9, A), (9, B), (9, D), (9, E)\}$$

$$n(S) = 12$$

$$(a) \{(3, A), (3, E), (9, A), (9, E)\}$$

$$\begin{aligned} \text{Kebarangkalian} &= \frac{4}{12} \\ &= \frac{1}{3} \end{aligned}$$

$$(b) \{(3, B), (3, D), (4, A), (4, B), (4, D), (4, E), (9, B), (9, D)\}$$

$$\begin{aligned} \text{Kebarangkalian} &= \frac{8}{12} \\ &= \frac{2}{3} \end{aligned}$$

$$2. n(S) = 9$$

$$(a) \{F, A, O, U, I, E\}$$

$$\begin{aligned} \text{Kebarangkalian} &= \frac{6}{9} \\ &= \frac{2}{3} \end{aligned}$$

$$(b) \{F, A, V, R, T\}$$

$$\text{Kebarangkalian} = \frac{5}{9}$$

$$3. n(S) = 36$$

$$(a) \{(1, 3), (2, 2), (3, 1), (1, 6), (2, 5), (3, 4), (4, 3), (5, 2), (6, 1)\}$$

$$\begin{aligned} \text{Kebarangkalian} &= \frac{9}{36} \\ &= \frac{1}{4} \end{aligned}$$

$$(b) \{(1, 2), (1, 4), (1, 6), (2, 2), (2, 4), (2, 6)\}$$

$$\begin{aligned} \text{Kebarangkalian} &= \frac{6}{36} \\ &= \frac{1}{6} \end{aligned}$$

$$4. n(S) = 25$$

$$(a) \{(6, 5), (6, 7), (6, 9), (8, 5), (8, 7), (8, 9)\}$$

$$\text{Kebarangkalian} = \frac{6}{25}$$

$$(b) \{(5, 7), (6, 8), (7, 5), (7, 9), (8, 6), (9, 7)\}$$

$$\text{Kebarangkalian} = \frac{6}{25}$$

Praktis Formatif: Kertas 1**1. B**

$$\text{Gandaan 3} = \{3, 6, 9\}$$

$$n(\text{Gandaan 3}) = 3$$

$$n(\text{set } P) = 10$$

$$P(\text{Gandaan 3}) = \frac{3}{10}$$

2. B

$$\text{Jumlah bilangan murid} = 60$$

$$\text{Bilangan murid lelaki pasukan } Q = 18$$

$$\begin{aligned} P(\text{murid lelaki pasukan } Q) &= \frac{18}{60} \\ &= \frac{3}{10} \end{aligned}$$

3. A

$$\frac{3}{5} \times \text{Jumlah ahli} = 18$$

$$\text{Jumlah ahli} = 30$$

$$\begin{aligned} \text{Bilangan ahli perempuan} &= 30 - 18 \\ &= 12 \end{aligned}$$

4. C

$$\begin{aligned} \text{Jumlah bilangan pen} &= 24 + 12 \\ &= 36 \end{aligned}$$

$$\begin{aligned} P(\text{Pen biru}) &= \frac{12}{36} \\ &= \frac{1}{3} \end{aligned}$$

5. D

$$\begin{aligned} \text{Bilangan peluang} &= \frac{2\,485}{10\,000} \times 100 \\ &= 24.85 \\ &\approx 25 \end{aligned}$$

6. A

$$\frac{3}{5} \times \text{Jumlah guli} = 9$$

$$\text{Jumlah guli} = 15$$

$$\begin{aligned} \text{Bilangan guli biru} &= 15 - 9 \\ &= 6 \end{aligned}$$

7. D

$$\begin{aligned} \text{Bilangan kad merah} &= \frac{2}{5} \times 90 \\ &= 36 \end{aligned}$$

Katakan x ialah bilangan kad merah yang ditambah

$$\frac{2}{3} \times (90 + x) = 36 + x$$

$$60 + \frac{2x}{3} = 36 + x$$

$$\frac{1}{3}x = 24$$

$$x = 72$$

8. D

$$\begin{aligned} \text{Bilangan guli merah} &= 8 + 7 \\ &= 15 \end{aligned}$$

$$\begin{aligned} \text{Jumlah bilangan guli} &= 8 + 27 + 7 + 3 \\ &= 45 \end{aligned}$$

$$\begin{aligned} P(\text{Guli merah}) &= \frac{15}{45} \\ &= \frac{1}{3} \end{aligned}$$

9. D

$$\begin{aligned}\text{Kebarangkalian} &= 1 - \frac{2}{16} \\ &= \frac{14}{16} \\ &= \frac{7}{8}\end{aligned}$$

10. D

$$\begin{aligned}\text{Kebarangkalian} &= 1 - \frac{4}{12} \\ &= \frac{8}{12} \\ &= \frac{2}{3}\end{aligned}$$

11. D

$$\begin{aligned}\text{Kebarangkalian lulus} &= 1 - \frac{1}{8} \\ &= \frac{7}{8} \\ \text{Bilangan murid lulus} &= \frac{7}{8} \times 48 \\ &= 42\end{aligned}$$

12. C

$$\begin{aligned}P(\text{bukan manik merah}) &= 1 - \frac{5}{12} \\ &= \frac{7}{12}\end{aligned}$$

$$\frac{7}{12} \times \text{Jumlah guli} = 21$$

$$\text{Jumlah guli} = 36$$

$$\begin{aligned}\text{Bilangan manik merah} &= 36 - 13 - 8 \\ &= 15\end{aligned}$$

$$\begin{aligned}P(\text{bukan manik putih}) &= \frac{13 + 15}{36} \\ &= \frac{28}{36} \\ &= \frac{7}{9}\end{aligned}$$

13. C

$$\begin{aligned}P(\text{Melayu}) &= \frac{20}{40} \\ &= \frac{1}{2}\end{aligned}$$

$$\begin{aligned}P(\text{bukan Cina}) &= \frac{1}{2} + \frac{1}{5} \\ &= \frac{7}{10}\end{aligned}$$

14. C

$$\begin{aligned}\text{Bilangan kotak mengandungi mentol pecah} &= 3 + 7 + 4 + 1 + 3 + 2 \\ &= 20\end{aligned}$$

$$\begin{aligned}P(\text{Kotak tidak mengandungi mentol pecah}) &= 1 - \frac{20}{60} \\ &= \frac{2}{3}\end{aligned}$$

15. B

$$\begin{aligned}\text{Jumlah bilangan ahli} &= 90 + 50 \\ &= 140\end{aligned}$$

$$\begin{aligned}P(\text{ahli lelaki}) &= 1 - \frac{3}{7} \\ &= \frac{4}{7}\end{aligned}$$

$$\begin{aligned}\text{Bilangan ahli lelaki} &= \frac{4}{7} \times 140 \\ &= 80\end{aligned}$$

16. D

$$\begin{aligned}\frac{3}{4} \times \text{Jumlah pekerja} &= 120 \\ \text{Jumlah pekerja} &= 160\end{aligned}$$

$$\begin{aligned}P(\text{pekerja tidak menaiki bas}) &= \frac{150}{160} \\ &= \frac{15}{16}\end{aligned}$$

17. D

$$\begin{aligned}\text{Bilangan kerani} &= \frac{1}{5} \times 360 \\ &= 72\end{aligned}$$

$$\begin{aligned}\text{Bilangan guru} &= 360 - 72 - 18 \\ &= 270\end{aligned}$$

18. B

$$\begin{aligned}S &= \{18, 19, 20, 21, 22, 23, 24, 25, 26, 27, 28, 29, \\ &\quad 30, 31, 32, 33, 34, 35, 36, 37, 38, 39, 40, 41\} \\ n(S) &= 24\end{aligned}$$

$$\begin{aligned}A &= \text{Nombor perdana} \\ A &= \{19, 23, 29, 37, 41\} \\ n(A) &= 6\end{aligned}$$

$$P(A) = \frac{6}{24}$$

$$\begin{aligned}P(\text{Bukan nombor perdana}) &= 1 - \frac{6}{24} \\ &= \frac{3}{4}\end{aligned}$$

Praktis Formatif: Kertas 2

1. (a)

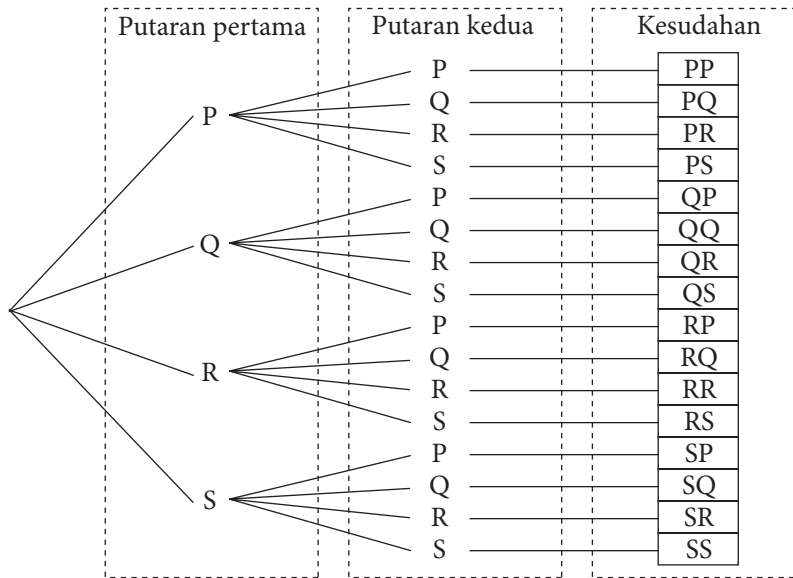

(b) (i) {PP, QQ, RR, SS}

$$\text{Kebarangkalian} = \frac{4}{16} = \frac{1}{4}$$

(ii) {PQ, QP, QQ, QR, QS, RQ, SQ}

$$\text{Kebarangkalian} = \frac{7}{16}$$

2. (a)

		Kesudahan putaran cakera			
		P	Q	R	S
Kesudahan balingan dadu	1	(1, P)	(1, Q)	(1, R)	(1, S)
	2	(2, P)	(2, Q)	(2, R)	(2, S)
	3	(3, P)	(3, Q)	(3, R)	(3, S)
	4	(4, P)	(4, Q)	(4, R)	(4, S)
	5	(5, P)	(5, Q)	(5, R)	(5, S)
	6	(6, P)	(6, Q)	(6, R)	(6, S)

(b) (i) {(1, R), (2, R), (3, R), (4, R), (5, R), (6, R)}

$$\text{Kebarangkalian} = \frac{6}{24} = \frac{1}{4}$$

(ii) {(1, Q), (2, P), (2, Q), (2, R), (2, S), (3, Q), (4, P), (4, Q), (4, R), (4, S), (5, Q), (6, P), (6, Q), (6, R), (6, S)}

$$\text{Kebarangkalian} = \frac{15}{24} = \frac{5}{8}$$

3. (a)

Putih	(W)	(1, W)	(2, W)	(3, W)	(4, W)	(5, W)	(6, W)
Hitam	(B)	(1, B)	(2, B)	(3, B)	(4, B)	(5, B)	(6, B)
Kuning	(Y)	(1, Y)	(2, Y)	(3, Y)	(4, Y)	(5, Y)	(6, Y)
		1	2	3	4	5	6

(b) (i) {(1, Y), (2, Y), (3, Y), (4, Y)}

$$\text{Kebarangkalian} = \frac{4}{18} = \frac{2}{9}$$

(ii) {(1, W), (2, W), (3, W), (4, W), (5, W), (6, W), (3, B), (4, B), (5, B), (6, B), (3, Y), (4, Y), (5, Y), (6, Y)}

$$\text{Kebarangkalian} = \frac{14}{18} = \frac{7}{9}$$

4. (a) {(Ahmad, Juan), (Ahmad, Kim), (Ahmad, Lenny), (Ryan, Juan), (Ryan, Kim), (Ryan, Lenny), (Clifford, Juan), (Clifford, Kim), (Clifford, Lenny), (Danny, Juan), (Danny, Kim), (Danny, Lenny)}
- (b) {(Clifford, Juan), (Danny, Juan)}
- $$\begin{aligned}\text{Kebarangkalian} &= \frac{2}{12} \\ &= \frac{1}{6}\end{aligned}$$
- (c) Kebarangkalian bahawa Ahmad dan Ryan bertugas bersama ialah tidak mungkin kerana hanya pasukan yang berlainan bertugas bersama.
5. (a) {(J, 20), (J, 50), (J, 100), (K, 20), (K, 50), (K, 100), (L, 20), (L, 50), (L, 100), (M, 20), (M, 50), (M, 100)}
- (b) (i) {(J, 100), (K, 20), (K, 50), (K, 100), (L, 100), (M, 100)}
- $$\begin{aligned}\text{Kebarangkalian} &= \frac{6}{12} \\ &= \frac{1}{2}\end{aligned}$$
- (ii) {(M, 50)}
- $$\begin{aligned}\text{Kebarangkalian} &= 1 - \frac{1}{12} \\ &= \frac{11}{12}\end{aligned}$$
6. (a) {(Q, R), (Q, S), (Q, I), (Q, U), (R, Q), (R, S), (R, I), (R, U), (S, Q), (S, R), (S, I), (S, U), (I, Q), (I, R), (I, S), (I, U), (U, Q), (U, R), (U, S), (U, I)}
- (b) (i) {(I, Q), (I, R), (I, S), (I, U), (U, Q), (U, R), (U, S), (U, I)}
- $$\begin{aligned}\text{Kebarangkalian} &= \frac{8}{20} \\ &= \frac{2}{5}\end{aligned}$$
- (ii) {(Q, I), (Q, U), (R, I), (R, U), (S, I), (S, U)}
- $$\begin{aligned}\text{Kebarangkalian} &= \frac{6}{20} \\ &= \frac{3}{10}\end{aligned}$$

FOKUS KBAT

(a)

Pakej	Pulau					
	Kapas (K)	Langkawi (L)	Perhentian (P)	Pangkor (Q)	Redang (R)	Tioman (T)
Santai (S)	(S, K)	(S, L)	(S, P)	(S, Q)	(S, R)	(S, T)
Ekstrem (E)	(E, K)	(E, L)	(E, P)	(E, Q)	(E, R)	(E, T)
Ekonomi (N)	(N, K)	(N, L)	(N, P)	(N, Q)	(N, R)	(N, T)
Mewah (M)	(M, K)	(M, L)	(M, P)	(M, Q)	(M, R)	(M, T)
Romantik (C)	(C, K)	(C, L)	(C, P)	(C, Q)	(C, R)	(C, T)

- (b) (i) {(S, L), (N, L), (C, L), (S, R), (N, R), (C, R)}

$$\begin{aligned}\text{Kebarangkalian} &= \frac{6}{30} \\ &= \frac{1}{5}\end{aligned}$$

- (ii) Pulau yang terletak di Selat Melaka ialah Pulau Langkawi dan Pulau Pangkor.
{(E, L), (M, L), (S, Q), (E, Q), (N, Q), (M, Q), (C, Q)}

$$\text{Kebarangkalian} = \frac{7}{10}$$

JAWAPAN

BAB 8: BEARING

8.1

A

1.

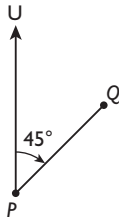

2.



3.

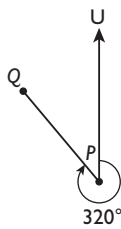

4.

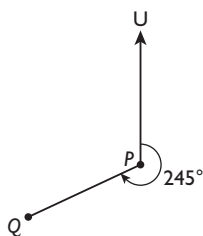

5.

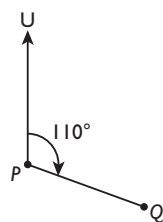

6.

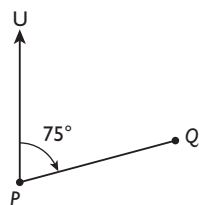

7.

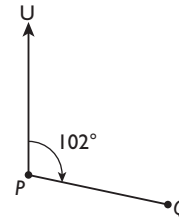

8.

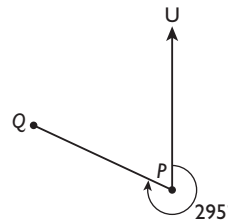

B

1.

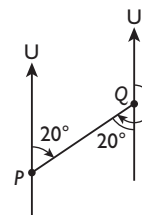

$$\begin{aligned} \text{Bearing } P \text{ dari } Q &= 180^\circ + 20^\circ \\ &= 200^\circ \end{aligned}$$

2.

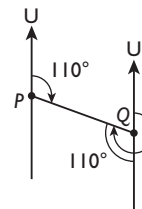

$$\begin{aligned} \text{Bearing } P \text{ dari } Q &= 180^\circ + 110^\circ \\ &= 290^\circ \end{aligned}$$

3.

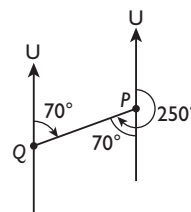

$$\begin{aligned} 250^\circ - 180^\circ &= 70^\circ \\ \text{Bearing } P \text{ dari } Q &= 070^\circ \end{aligned}$$

4.

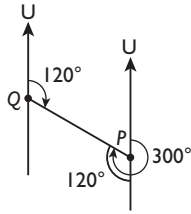

$$300^\circ - 180^\circ = 120^\circ$$

Bearing P dari $Q = 120^\circ$

5.

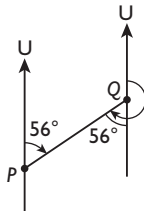

Bearing P dari Q
 $= 180^\circ + 56^\circ$
 $= 236^\circ$

6.

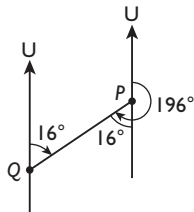

$$196^\circ - 180^\circ = 16^\circ$$

Bearing P dari $Q = 016^\circ$

7.

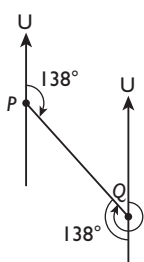

Bearing P dari Q
 $= 180^\circ + 138^\circ$
 $= 318^\circ$

8.

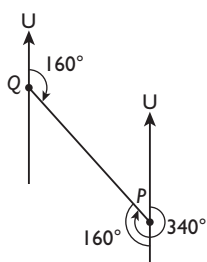

$$340^\circ - 180^\circ = 160^\circ$$

Bearing P dari $Q = 160^\circ$

C

1.

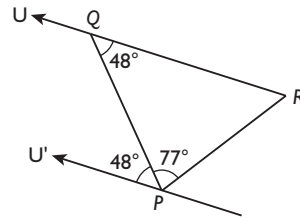

$$\angle U'PQ = \angle RQP = 48^\circ$$

Bearing R dari $P = 48^\circ + 77^\circ$
 $= 125^\circ$

2.

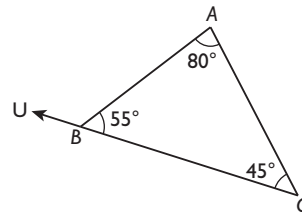

$$\angle ACB = 180^\circ - 80^\circ - 55^\circ$$

$$= 45^\circ$$

Bearing A dari $C = 045^\circ$

3.

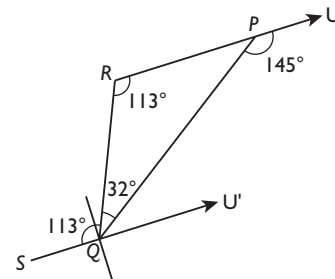

$$\angle PRQ = 145^\circ - 32^\circ = 113^\circ$$

$$\angle RQS = \angle PRQ = 113^\circ$$

Bearing R dari $Q = 180^\circ + 113^\circ$
 $= 293^\circ$

Praktis Formatif: Kertas 1

1. B

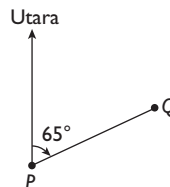

2. C

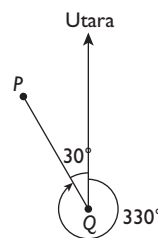

3. A

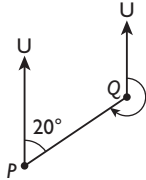

$$\begin{aligned} \text{Bearing } P \text{ dari } Q &= 180^\circ + 20^\circ \\ &= 200^\circ \end{aligned}$$

4. A

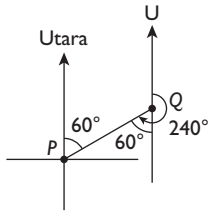

$$60^\circ + 180^\circ = 240^\circ$$

5. C

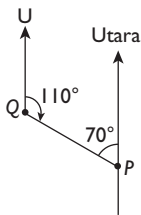

$$180^\circ - 70^\circ = 110^\circ$$

6. C

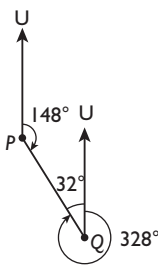

$$\begin{aligned} 360^\circ - 328^\circ &= 32^\circ \\ \text{Bearing } Q \text{ dari } P &= 180^\circ - 32^\circ \\ &= 148^\circ \end{aligned}$$

7. D

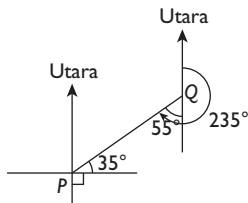

$$\begin{aligned} 90^\circ + 35^\circ &= 125^\circ \\ 180^\circ - 125^\circ &= 55^\circ \\ 55^\circ + 180^\circ &= 235^\circ \end{aligned}$$

8. D

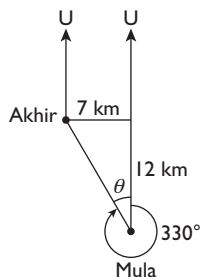

$$\theta = \tan^{-1} \frac{7}{12} = 30^\circ$$

$$\text{Bearing} = 360^\circ - 30^\circ = 330^\circ$$

9. B

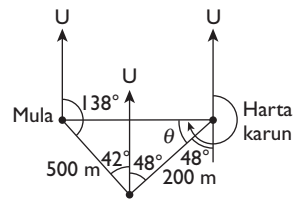

$$\tan \theta = \frac{500}{200}$$

$$\theta = 68^\circ 12'$$

$$\begin{aligned} \text{Bearing} &= 180^\circ + 68^\circ 12' + 48^\circ \\ &= 296^\circ 12' \end{aligned}$$

10. C

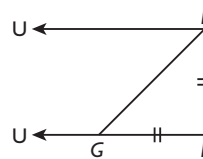

11. C

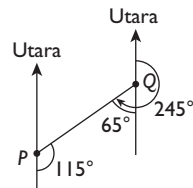

$$180^\circ - 115^\circ = 65^\circ$$

$$\begin{aligned} \text{Bearing titik } P \text{ dari titik } Q &= 65^\circ + 180^\circ \\ &= 245^\circ \end{aligned}$$

12. C

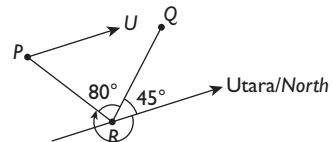

$$\begin{aligned} \text{Bearing } P \text{ dari } R &= 360^\circ - 80^\circ - 45^\circ \\ &= 235^\circ \end{aligned}$$

13. B

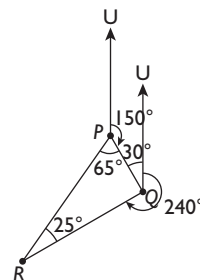

$$180^\circ - 150^\circ = 30^\circ$$

$$\begin{aligned} \angle PQR &= 360^\circ - 240^\circ - 30^\circ \\ &= 90^\circ \end{aligned}$$

$$\begin{aligned} \angle QPR &= 180^\circ - 90^\circ - 25^\circ \\ &= 65^\circ \end{aligned}$$

$$\text{Bearing } R \text{ dari } P$$

$$= 150^\circ + 65^\circ$$

$$= 215^\circ$$

14. D

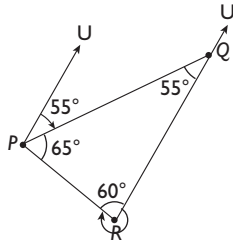

$$\begin{aligned}\angle PRQ &= 180^\circ - 65^\circ - 55^\circ \\ &= 60^\circ\end{aligned}$$

$$\begin{aligned}\text{Bearing } P \text{ dari } R &= 360^\circ - 60^\circ \\ &= 300^\circ\end{aligned}$$

15. B

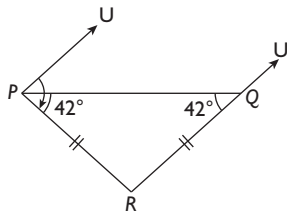

$$\begin{aligned}\text{Bearing } R \text{ dari } P &= 42^\circ + 42^\circ \\ &= 084^\circ\end{aligned}$$

16. B

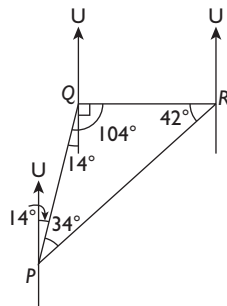

$$\begin{aligned}180^\circ - 42^\circ - 34^\circ &= 104^\circ \\ 104^\circ - 90^\circ &= 14^\circ\end{aligned}$$

$$\begin{aligned}\text{Bearing } R \text{ dari } P &= 14^\circ + 34^\circ \\ &= 048^\circ\end{aligned}$$

FOKUS KBAT

$$\angle UTK = \angle TKS = 50^\circ$$

$$\angle SKP = 180^\circ - 140^\circ = 40^\circ$$

$$\angle TKP = 50^\circ + 40^\circ = 90^\circ$$

$$\tan \angle KTP = \frac{2.4}{1.5}$$

$$\begin{aligned}\angle KTP &= \tan^{-1} \frac{2.4}{1.5} \\ &= 58^\circ\end{aligned}$$

$$\angle UTP = 50^\circ + 58^\circ = 108^\circ$$

$$\begin{aligned}\text{Bearing } T \text{ dari } P &= 180^\circ + 108^\circ \\ &= 288^\circ \quad (\text{C})\end{aligned}$$

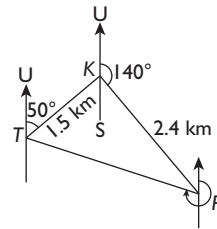

JAWAPAN

BAB 9: BUMI SEBAGAI SFERA

9.1

A

1. 74°T
2. 102°T
3. 33°B
4. 118°B
5. 155°B

B

1.

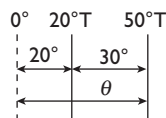
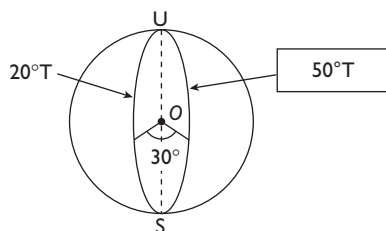

$$\begin{aligned}\theta &= 20^\circ + 30^\circ \\ &= 50^\circ\end{aligned}$$

2.

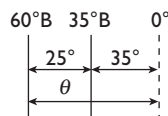
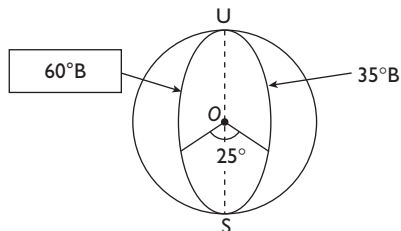

$$\begin{aligned}\theta &= 35^\circ + 25^\circ \\ &= 60^\circ\end{aligned}$$

3.

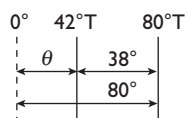
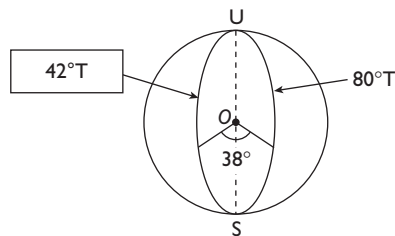

$$\begin{aligned}\theta &= 80^\circ - 38^\circ \\ &= 42^\circ\end{aligned}$$

4.

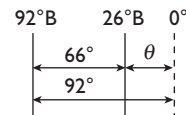
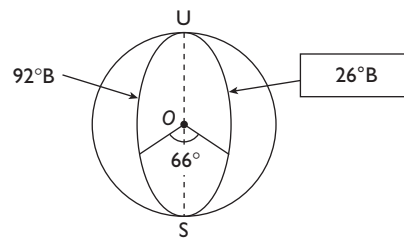

$$\begin{aligned}\theta &= 92^\circ - 66^\circ \\ &= 26^\circ\end{aligned}$$

5.

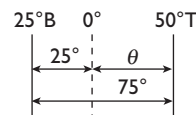
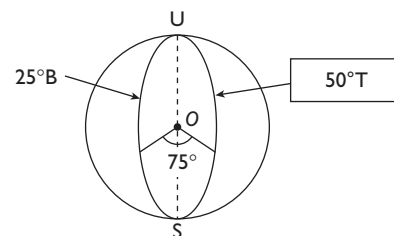

$$\begin{aligned}\theta &= 75^\circ - 25^\circ \\ &= 50^\circ\end{aligned}$$

6.

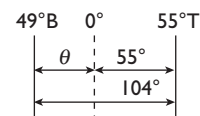
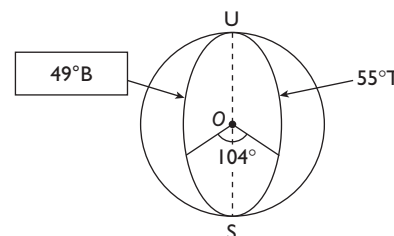

$$\begin{aligned}\theta &= 104^\circ - 55^\circ \\ &= 49^\circ\end{aligned}$$

7.

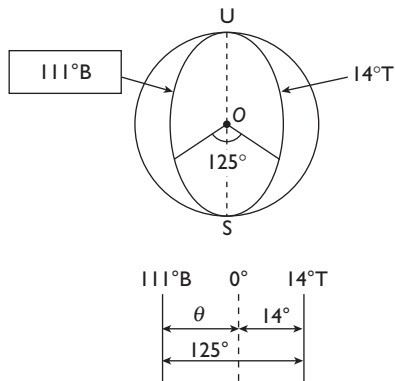

$$\begin{aligned}\theta &= 125^\circ - 14^\circ \\ &= 111^\circ\end{aligned}$$

C

1. Longitud Q = $(180^\circ - 120^\circ)T$
= $60^\circ T$
2. Longitud Q = $(180^\circ - 72^\circ)B$
= $108^\circ B$
3. Longitud Q = $(180^\circ - 25^\circ)T$
= $155^\circ T$
4. Longitud Q = $(180^\circ - 69^\circ)B$
= $111^\circ B$
5. Longitud Q = $(180^\circ - 138^\circ)B$
= $42^\circ B$

D

1. Beza = $80^\circ - 14^\circ = 66^\circ$
2. Beza = $41^\circ 20' - 8^\circ 50' = 32^\circ 30'$
3. Beza = $25^\circ + 55^\circ = 80^\circ$
4. Beza = $57^\circ 38' + 45^\circ 29' = 103^\circ 7'$

9.2

A

1. Latitud P = $30^\circ U$
2. Latitud P = $55^\circ U$
3. Latitud P = $46^\circ S$
4. Latitud P = $71^\circ S$
5. Latitud P = $(90^\circ - 42^\circ)U = 48^\circ U$

B

1. Latitud P = $(110^\circ - 38^\circ)U$
= $72^\circ U$
2. Latitud P = $(85^\circ - 56^\circ)S$
= $29^\circ S$
3. Latitud P = $(23^\circ + 20^\circ)U$
= $43^\circ U$
4. Latitud P = $(65^\circ - 34^\circ)S$
= $31^\circ S$
5. Latitud P = $(100^\circ - 48^\circ)U$
= $52^\circ U$

C

1. Beza = $70^\circ - 25^\circ = 45^\circ$
2. Beza = $120^\circ - 42^\circ = 78^\circ$
3. Beza = $32^\circ 40' - 9^\circ 15' = 23^\circ 25'$
4. Beza = $31^\circ + 69^\circ = 100^\circ$
5. Beza = $56^\circ + 38^\circ = 94^\circ$
6. Beza = $15^\circ 48' + 67^\circ 53' = 83^\circ 41'$

9.3

A

- B ($60^\circ U, 12^\circ B$)
C ($48^\circ S, 64^\circ B$)
D ($0^\circ, 35^\circ T$)
F ($48^\circ S, 12^\circ B$)
H ($48^\circ S, 35^\circ T$)
J ($60^\circ U, 168^\circ T$)
K ($48^\circ S, 168^\circ T$)

B

1. Latitud Q = $40^\circ S$
Longitud Q = $(180^\circ - 80^\circ)B$
= $100^\circ B$
 \therefore Kedudukan Q = ($40^\circ S, 100^\circ B$)
2. Latitud Q = $55^\circ S$
Longitud Q = $(180^\circ - 105^\circ)T$
= $75^\circ T$
 \therefore Kedudukan Q = ($55^\circ S, 75^\circ T$)
3. Latitud Q = $38^\circ U$
Longitud Q = $(180^\circ - 125^\circ)B$
= $55^\circ B$
 \therefore Kedudukan Q = ($38^\circ U, 55^\circ B$)
4. Latitud Q = Latitud P = $60^\circ U$
Longitud Q = $(180^\circ - 110^\circ)B$
= $70^\circ B$
 \therefore Kedudukan Q = ($60^\circ U, 70^\circ B$)
5. Latitud Q = Latitud P = $24^\circ S$
Longitud Q = $(180^\circ - 50^\circ)T$
= $130^\circ T$
 \therefore Kedudukan Q = ($24^\circ S, 130^\circ T$)

9.4

A

1. $\angle POQ = 70^\circ - 50^\circ = 20^\circ$
Jarak PQ = 20×60
= 1 200 batu nautika
2. $\angle POQ = 45^\circ + 31^\circ = 76^\circ$
Jarak PQ = 76×60
= 4 560 batu nautika
3. $\angle POQ = 68^\circ + 42^\circ = 110^\circ$
Jarak PQ = 110×60
= 6 600 batu nautika

B

1. Beza latitud = $14^\circ + 36^\circ$
= 50°
Jarak $GH = 50 \times 60$
= 3 000 batu nautika
2. Beza latitud = $75^\circ - 49^\circ$
= 26°
Jarak $JK = 26 \times 60$
= 1 560 batu nautika
3. Beza latitud = $80^\circ - 20^\circ$
= 60°
Jarak $PQ = 60 \times 60$
= 3 600 batu nautika
4. Beza latitud = $90^\circ - 12^\circ$
= 78°
Jarak $CD = 78 \times 60$
= 4 680 batu nautika
5. Beza latitud = $29^\circ + 23^\circ$
= 52°
Jarak $XY = 52 \times 60$
= 3 120 batu nautika

C

1. $\angle POQ = \frac{4\,200}{60} = 70^\circ$
Latitud $Q = (70^\circ - 55^\circ)S$
= $15^\circ S$
2. $\angle POQ = \frac{5\,520}{60} = 92^\circ$
Latitud $Q = (92^\circ - 65^\circ)U$
= $27^\circ U$
3. $\angle POQ = \frac{1\,620}{60} = 27^\circ$
Latitud $Q = (25^\circ + 27^\circ)U$
= $52^\circ U$
4. $\angle POQ = \frac{2\,700}{60} = 45^\circ$
Latitud $Q = (75^\circ - 45^\circ)U$
= $30^\circ U$
5. $\angle POQ = \frac{4\,860}{60} = 81^\circ$
Latitud $Q = (81^\circ - 63^\circ)S$
= $18^\circ S$

D

1. Beza longitud = $60^\circ - 35^\circ$
= 25°
Jarak $PQ = 25 \times 60$
= 1 500 batu nautika
2. Beza longitud = $50^\circ - 36^\circ$
= 14°
Jarak $PQ = 14 \times 60$
= 840 batu nautika
3. Beza longitud = $115^\circ - 46^\circ$
= 69°
Jarak $PQ = 69 \times 60$
= 4 140 batu nautika
4. Beza longitud = $57^\circ + 24^\circ$
= 81°
Jarak $PQ = 81 \times 60$
= 4 860 batu nautika
5. Beza longitud = $21^\circ + 104^\circ$
= 125°
Jarak $PQ = 125 \times 60$
= 7 500 batu nautika

E

1. Beza longitud = $\frac{1\,680}{60} = 28^\circ$
Longitud $D = (72^\circ + 28^\circ)B$
= $100^\circ B$
2. Beza longitud = $\frac{5\,160}{60} = 86^\circ$
Longitud $D = (86^\circ - 48^\circ)T$
= $38^\circ T$
3. Beza longitud = $\frac{4\,440}{60} = 74^\circ$
Longitud $D = (100^\circ - 74^\circ)T$
= $26^\circ T$
4. Beza longitud = $\frac{2\,160}{60} = 36^\circ$
Longitud $D = (76^\circ - 36^\circ)B$
= $40^\circ B$
5. Beza longitud = $\frac{3\,840}{60} = 64^\circ$
Longitud $D = (50^\circ + 64^\circ)T$
= $114^\circ T$

F

1. Beza longitud = $102^\circ - 58^\circ$
= 44°
Jarak $PQ = 44 \times 60 \times \cos 60^\circ$
= 1 320 batu nautika
2. Beza longitud = $100^\circ - 32^\circ$
= 68°
Jarak $PQ = 68 \times 60 \times \cos 30^\circ$
= 3 533.38 batu nautika
3. Beza longitud = $126^\circ - 81^\circ$
= 45°
Jarak $PQ = 45 \times 60 \times \cos 55^\circ$
= 1 548.66 batu nautika
4. Beza longitud = $18^\circ + 48^\circ$
= 66°
Jarak $PQ = 66 \times 60 \times \cos 15^\circ$
= 3 825.07 batu nautika
5. Beza longitud = $36^\circ + 112^\circ$
= 148°
Jarak $PQ = 148 \times 60 \times \cos 56^\circ$
= 4 965.63 batu nautika

G

1. Beza longitud = $\frac{1\ 950}{60 \times \cos 60^\circ}$
= 65°
Longitud $Q = (15^\circ + 65^\circ)B$
= $80^\circ B$
2. Beza longitud = $\frac{4\ 050}{60 \times \cos 60^\circ}$
= 135°
Longitud $Q = (135^\circ - 85^\circ)T$
= $50^\circ T$
3. Beza longitud = $\frac{1\ 800}{60 \times \cos 15^\circ}$
= 31.1° atau $31^\circ 3'$
Longitud $Q = (50^\circ + 31.1^\circ)T$
= $81.1^\circ T$ atau $81^\circ 3' T$
4. Beza longitud = $\frac{2\ 640}{60 \times \cos 30^\circ}$
= 50.8° atau $50^\circ 48'$
Longitud $Q = (50.8^\circ - 10^\circ)B$
= $40.8^\circ B$ atau $40^\circ 48' B$

H

1. $\theta = 180^\circ - (2 \times 25^\circ)$
= 130°
Jarak terpendek FG
= 130×60
= 7 800 batu nautika
2. $\theta = 180^\circ - 70^\circ - 45^\circ$
= 65°
Jarak terpendek PQ
= 65×60
= 3 900 batu nautika
3. $\theta = 180^\circ - 47^\circ - 65^\circ$
= 68°
Jarak terpendek CD
= 68×60
= 4 080 batu nautika
4. $\theta = 180^\circ - 48^\circ + 12^\circ$
= 144°
Jarak terpendek KL
= 144×60
= 8 640 batu nautika

I

1. (a) Beza longitud = $\frac{5\ 070}{60} = 84.5^\circ$
 $\therefore \theta = 84.5^\circ - 18^\circ$
= 66.5° atau $66^\circ 30'$
(b) Jarak $PR = 56 \times 60$
= 3 360 batu nautika
(c) Jumlah jarak yang dilalui
= Jarak PR + Jarak RV
= $3\ 360 + (42 \times 60 \times \cos 56^\circ)$
= 4 769.17 batu nautika
Jumlah masa yang diambil
= $\frac{4\ 769.17}{800}$
= 5 jam 58 minit
2. (a) Latitud $D = 52^\circ S$
Longitud $D = (180^\circ - 40^\circ)T$
= $140^\circ T$
Kedudukan $D = (52^\circ S, 140^\circ T)$
(b) $\theta = 30^\circ + 52^\circ = 82^\circ$
Jarak $CD = 82 \times 60$
= 4 920 batu nautika
(c) Masa yang diambil = $\frac{4\ 920}{750}$
= 6.56 jam
(d) $\theta = 180^\circ - 52^\circ - 30^\circ = 98^\circ$
Jarak terpendek $AC = 98 \times 60$
= 5 880 batu nautika

Praktis Formatif: Kertas 1

1. B

$$\begin{aligned} \text{Longitud } Q &= (180^\circ - 130^\circ)\text{B} \\ &= 50^\circ\text{B} \end{aligned}$$

2. C

$$40^\circ - 10^\circ = 30^\circ\text{T}$$

Bandar C berada di timur X dengan beza longitud 40°.

3. C

$$\begin{aligned} \text{Beza longitud } P \text{ dan } R &= 40^\circ + 80^\circ \\ &= 120^\circ \end{aligned}$$

$$\begin{aligned} \text{Beza longitud } P \text{ dan } Q &= 120^\circ \div 5 \\ &= 24^\circ \end{aligned}$$

$$\begin{aligned} \text{Longitud } Q &= (40^\circ - 24^\circ)\text{B} \\ &= 16^\circ\text{B} \end{aligned}$$

4. B

$$\begin{aligned} \text{Latitud } Q &= (55^\circ - 20^\circ)\text{U} \\ &= 35^\circ\text{U} \end{aligned}$$

5. A

$$\begin{aligned} \text{Beza longitud } K \text{ dan } M &= 80^\circ + 70^\circ \\ &= 150^\circ \end{aligned}$$

$$\begin{aligned} KL : LM &= 3 : 2 \\ 150^\circ \div 5 &= 30^\circ \end{aligned}$$

$$\begin{aligned} \text{Beza longitud } L \text{ dan } M &= 30^\circ \times 2 \\ &= 60^\circ \end{aligned}$$

$$\begin{aligned} \text{Latitud } L &= (70^\circ - 60^\circ)\text{S} \\ &= 10^\circ\text{S} \end{aligned}$$

6. A

$$30^\circ\text{S}$$

7. D

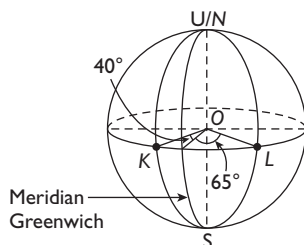

8. B

$$\begin{aligned} \text{Latitud } P &= (90^\circ - 50^\circ)\text{U} \\ &= 40^\circ\text{U} \end{aligned}$$

$$\begin{aligned} \text{Longitud } P &= (180^\circ - 30^\circ)\text{B} \\ &= 150^\circ\text{B} \end{aligned}$$

$$\text{Kedudukan } P = (40^\circ\text{U}, 150^\circ\text{B})$$

9. D

$$\text{Latitud } Q = 30^\circ\text{U}$$

$$\begin{aligned} \text{Longitud } Q &= (120^\circ + 20^\circ)\text{T} \\ &= 140^\circ\text{T} \end{aligned}$$

$$\text{Kedudukan } Q = (30^\circ\text{U}, 140^\circ\text{T})$$

10. A

$$\begin{aligned} \text{Latitud } P &= (90^\circ \times 46^\circ)\text{U} \\ &= 44^\circ\text{U} \end{aligned}$$

$$\begin{aligned} \text{Longitud } P &= (75^\circ - 15^\circ)\text{B} \\ &= 60^\circ\text{B} \end{aligned}$$

$$\text{Kedudukan } P = (44^\circ\text{U}, 60^\circ\text{B})$$

11. A

$$\text{Latitud } L = 30^\circ\text{U}$$

$$\text{Longitud } L = 100^\circ\text{T}$$

$$\text{Kedudukan } L = (30^\circ\text{U}, 100^\circ\text{T})$$

12. B

$$\text{Latitud } R = 38^\circ\text{S}$$

$$\begin{aligned} \text{Longitud } R &= (180^\circ - 46^\circ)\text{B} \\ &= 134^\circ\text{B} \end{aligned}$$

$$\text{Kedudukan } R = (38^\circ\text{S}, 134^\circ\text{B})$$

13. D

$$\begin{aligned} \text{Latitud } Q &= (80^\circ - 45^\circ)\text{U} \\ &= 35^\circ\text{U} \end{aligned}$$

$$\begin{aligned} \text{Longitud } P &= (20^\circ + 30^\circ)\text{B} \\ &= 50^\circ\text{B} \end{aligned}$$

$$\begin{aligned} \text{Longitud } Q &= (180^\circ - 50^\circ)\text{T} \\ &= 130^\circ\text{T} \end{aligned}$$

$$\text{Kedudukan } Q = (35^\circ\text{U}, 130^\circ\text{T})$$

14. B

Latitud kapal kuning

$$= 12^\circ\text{U} \leftarrow \text{Terletak di antara } 2^\circ\text{S dan } 30^\circ\text{U}$$

Longitud kapal kuning = 125°T

$$\begin{aligned} \text{Kedudukan kapal kuning} &= (12^\circ\text{U}, 125^\circ\text{T}) \end{aligned}$$

15. A

$$\begin{aligned} \text{Beza latitud} &= \frac{6\ 900}{60} \\ &= 115^\circ \end{aligned}$$

$$\begin{aligned} \text{Latitud } R &= (115^\circ - 90^\circ)\text{U} \\ &= 25^\circ\text{U} \end{aligned}$$

16. D

$$\begin{aligned} \text{Beza longitud } K \text{ dan } L & \\ &= \frac{2\,400}{60} \\ &= 40^\circ \\ \text{Longitud } L &= (40^\circ - 30^\circ)\text{T} \\ &= 10^\circ\text{T} \\ \text{Beza latitud } L \text{ dan } M & \\ &= \frac{4\,200}{60} \\ &= 70^\circ \\ \text{Latitud } M &= (70^\circ - 60^\circ)\text{S} \\ &= 10^\circ\text{S} \\ \text{Kedudukan } M &= (10^\circ\text{S}, 10^\circ\text{T}) \end{aligned}$$

17. A

$$\begin{aligned} \text{Beza longitud } Q \text{ dan } V & \\ &= \frac{3\,060}{60} \\ &= 51^\circ \\ \text{Longitud } V &= (51^\circ - 16^\circ)\text{T} \\ &= 35^\circ\text{T} \end{aligned}$$

18. D

$$\begin{aligned} \text{Latitud } Q &= \text{Latitud } R \\ &= (60^\circ \times 12^\circ)\text{U} \\ &= 48^\circ\text{U} \\ \text{Longitud } R &= (20^\circ + 50^\circ)\text{T} \\ &= 70^\circ\text{T} \\ \text{Kedudukan } R &= (48^\circ\text{U}, 70^\circ\text{T}) \end{aligned}$$

Praktis Formatif: Kertas 2

1. (a) Latitud $K = 40^\circ\text{U}$
 Longitud $K = (180^\circ - 15^\circ)\text{B}$
 $= 165^\circ\text{B}$
 Kedudukan bagi $K = (40^\circ\text{U}, 165^\circ\text{B})$
- (b) Beza longitud $= \frac{3\,360}{60}$
 $= 56^\circ$
 Longitud bagi $F = (56^\circ - 15^\circ)\text{B}$
 $= 41^\circ\text{B}$
- (c) Jarak $JH = 56 \times 60 \times \cos 40^\circ$
 $= 2\,573.91$ batu nautika
- (d) Beza longitud $KJ = 165^\circ - 41^\circ$
 $= 124^\circ$
 Jarak $KJ = 124 \times 60 \times \cos 40^\circ$
 $= 5\,699.37$ batu nautika
 Jarak $JF = 40 \times 60$
 $= 2\,400$ batu nautika
 Jumlah jarak $= 5\,699.37 + 2\,400$
 $= 8\,099.37$ batu nautika

$$\begin{aligned} \text{Jumlah masa} &= \frac{8\,099.37}{60} \\ &= 13.5 \text{ jam} \end{aligned}$$

2. (a) (i) 54°U
 (ii) Latitud $Q = 0^\circ$
 Longitud $Q = (110^\circ - 84^\circ)\text{T}$
 $= 26^\circ\text{T}$
 \therefore Kedudukan bagi $Q = (0^\circ, 26^\circ\text{T})$
- (b) Beza latitud $= \frac{3\,720}{60}$
 $= 62^\circ$
 Latitud $M = (62^\circ - 54^\circ)\text{S}$
 $= 8^\circ\text{S}$
- (c) Jarak $PR = 110 \times 60 \times \cos 54^\circ$
 $= 3\,879.38$ batu nautika
- (d) Laju purata $= \frac{3\,720}{60}$
 $= 620$ knot
3. (a) Longitud $C = (180^\circ - 35^\circ)\text{T}$
 $= 145^\circ\text{T}$
- (b) Beza longitud $= 35^\circ + 70^\circ$
 $= 105^\circ$
 Jarak $AB = 105 \times 60 \times \cos 46^\circ$
 $= 4\,376.35$ batu nautika
- (c) Katakan O ialah pusat bumi.
 $\angle POQ = \frac{4\,080}{60}$
 $= 68^\circ$
 Latitud $D = (68^\circ - 46^\circ)\text{S}$
 $= 22^\circ\text{S}$
- (d) Jumlah jarak $= 4\,376.35 + 4\,080$
 $= 8\,456.35$ batu nautika
 Jumlah masa $= \frac{8\,456.3}{550}$
 $= 15.38$ jam
4. (a) Longitud $R = (180^\circ - 60^\circ)\text{T}$
 $= 120^\circ\text{T}$
- (b) Katakan beza longitud di antara V dan $R = q^\circ$
 $q \times 60 \times \cos 30^\circ = 2\,550$
 $q = \frac{2\,550}{60 \times \cos 30^\circ}$
 $= 49^\circ$
 \therefore Longitud $V = (120^\circ - 49^\circ)\text{T}$
 $= 71^\circ\text{T}$
- (c) Beza latitud $= 180^\circ - 30^\circ - 50^\circ$
 $= 100^\circ$
 Jarak terpendek $PQ = 60 \times 100$
 $= 6\,000$ batu nautika

$$\begin{aligned}
 \text{(d) (i) Beza latitud} &= 50^\circ + 30^\circ \\
 &= 80^\circ \\
 \text{Jarak } RQ &= 80 \times 60 \\
 &= 4\,800 \text{ batu nautika} \\
 \text{(ii) Jumlah jarak} &= 2\,550 + 4\,800 \\
 &= 7\,350 \text{ batu nautika} \\
 \text{Jumlah masa} &= \frac{7\,350}{650} \\
 &= 11.3 \text{ jam}
 \end{aligned}$$

$$\begin{aligned}
 \text{5. (a) Longitud } V &= (180^\circ - 40^\circ)B \\
 &= 140^\circ B
 \end{aligned}$$

$$\begin{aligned}
 \text{(b) } \angle POR &= \frac{3\,000}{60} \\
 &= 50^\circ
 \end{aligned}$$

$$\begin{aligned}
 \text{Latitud } R &= (50 - 25)^\circ S \\
 &= 25^\circ S
 \end{aligned}$$

$$\begin{aligned}
 \text{(c) Jarak terpendek dari } P \text{ ke } V \\
 &= (65 + 65) \times 60 \\
 &= 130 \times 60 \\
 &= 7\,800 \text{ batu nautika}
 \end{aligned}$$

$$\begin{aligned}
 \text{(d) (i) Jarak } PQ \\
 &= (40 + 30) \times 60 \times \cos 25^\circ \\
 &= 3\,806.5 \text{ batu nautika} \\
 \text{(ii) Jumlah jarak} &= 3\,000 + 3\,806.5 \\
 &= 6\,806.5 \text{ batu nautika} \\
 \text{Laju purata} &= \frac{6\,806.5}{11.5} \\
 &= 591.9 \text{ knot}
 \end{aligned}$$

$$\text{6. (a) Kedudukan bagi } J = (65^\circ S, 25^\circ B)$$

$$\begin{aligned}
 \text{(b) Beza latitud} &= 180^\circ - 55^\circ - 55^\circ \\
 &= 70^\circ \\
 \text{Jarak terpendek} &= 70^\circ \times 60 \\
 &= 4\,200 \text{ batu nautika}
 \end{aligned}$$

$$\begin{aligned}
 \text{(c) Jarak } JK &= (25^\circ + 110^\circ) \times 60 \times \cos 65^\circ \\
 &= 135^\circ \times 60 \times \cos 65^\circ \\
 &= 3\,423.21 \text{ batu nautika}
 \end{aligned}$$

$$\begin{aligned}
 \text{(d) Katakan } x &= \text{Jumlah jarak dari } G \text{ ke } R \\
 720 &= \frac{x}{6.25} \\
 x &= 4\,500 \text{ batu nautika} \\
 \text{Beza latitud} &= 4\,500 \div 60 \\
 &= 75^\circ \\
 \text{Latitud } R &= 75^\circ - 55^\circ \\
 &= 20^\circ S
 \end{aligned}$$

JAWAPAN

BAB 10: PELAN DAN DONGAKAN

10.1

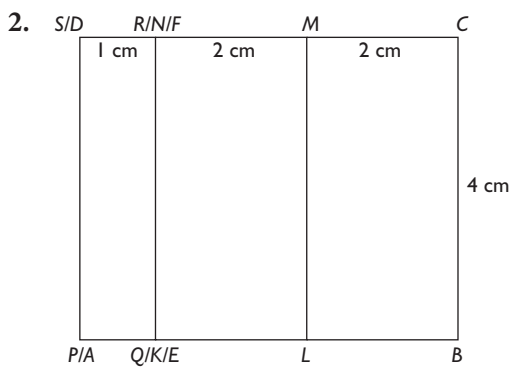
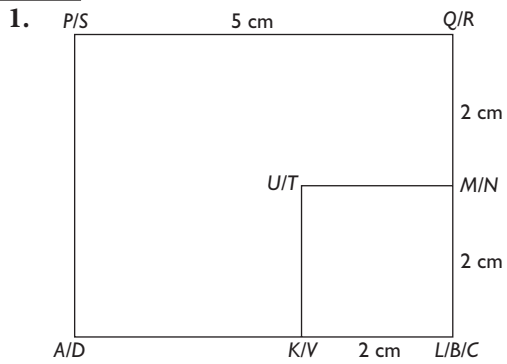

10.2

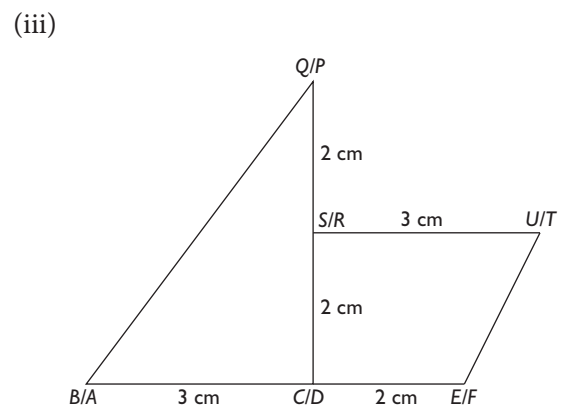
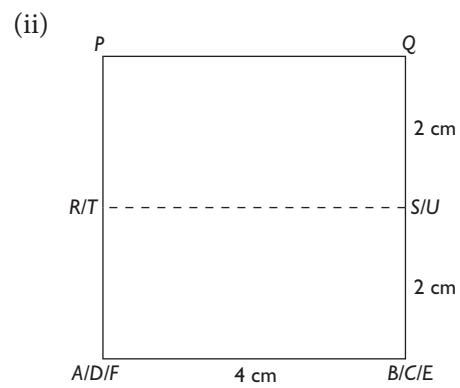
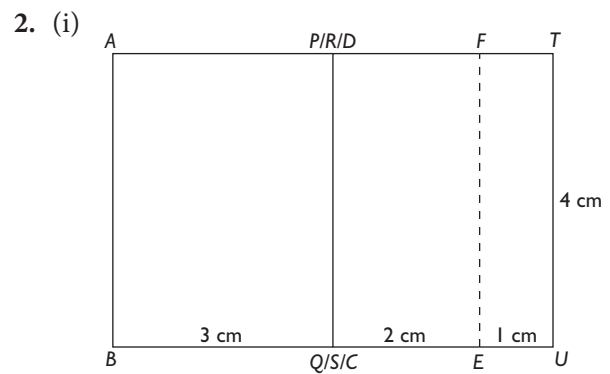
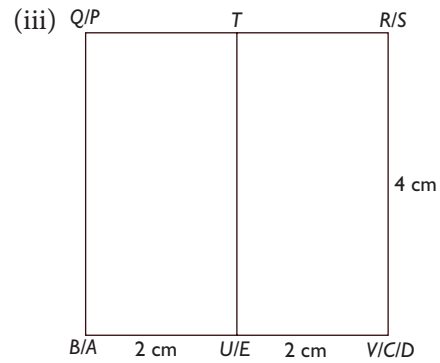
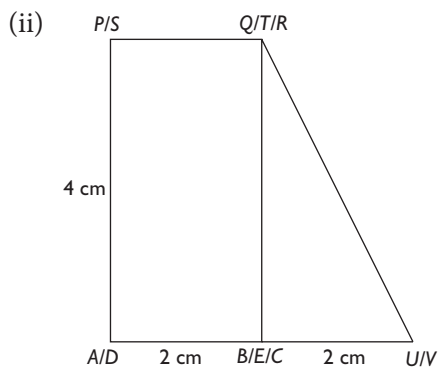
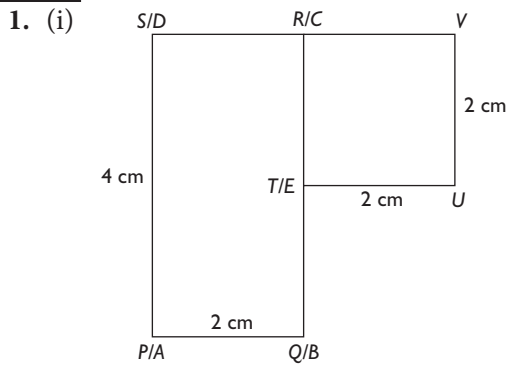

3. (i)

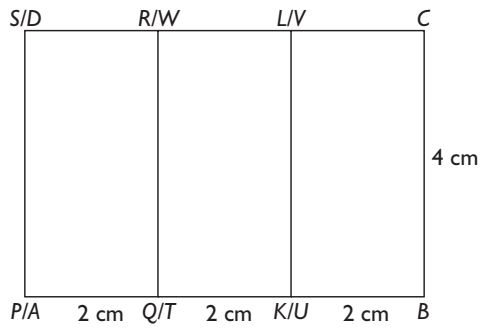

(ii)

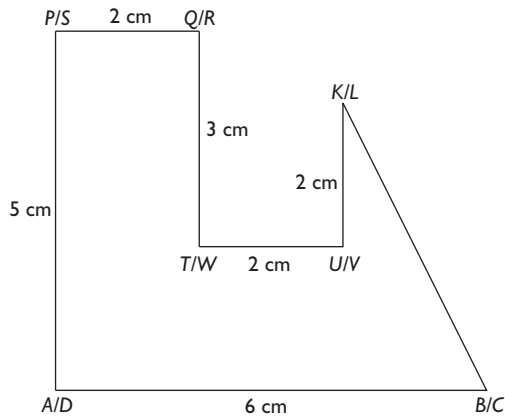

(iii)

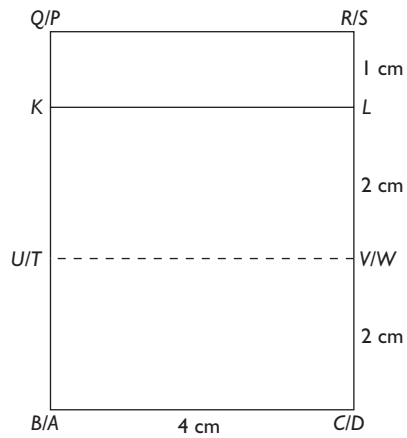

Praktis Formatif: Kertas 2

1. (a)

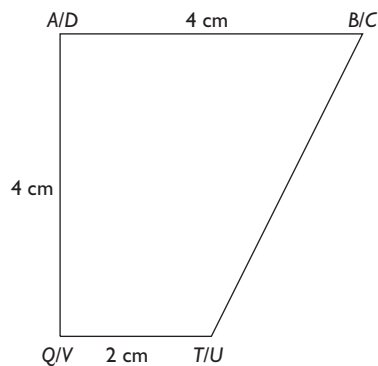

(b) (i)

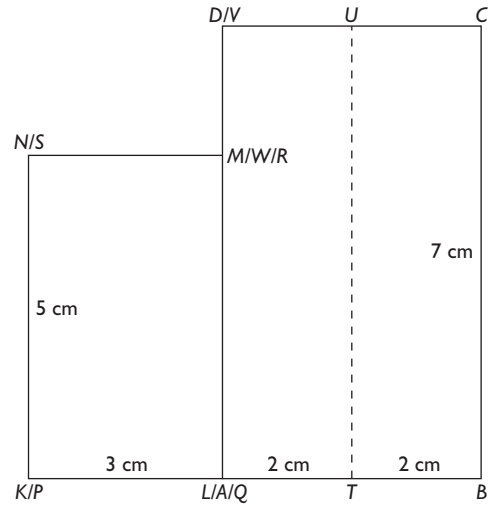

(ii)

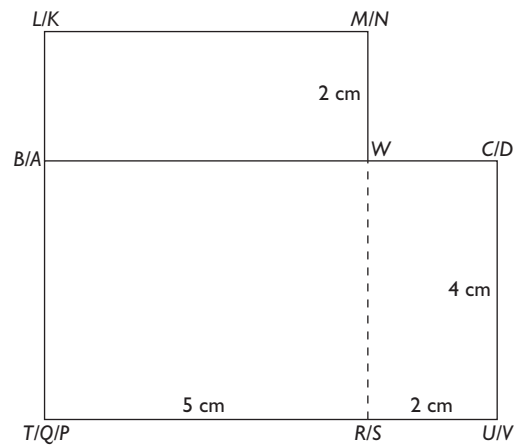

2. (a)

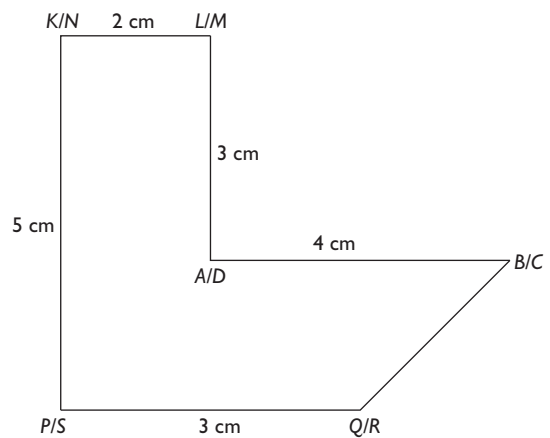

(b) (i)

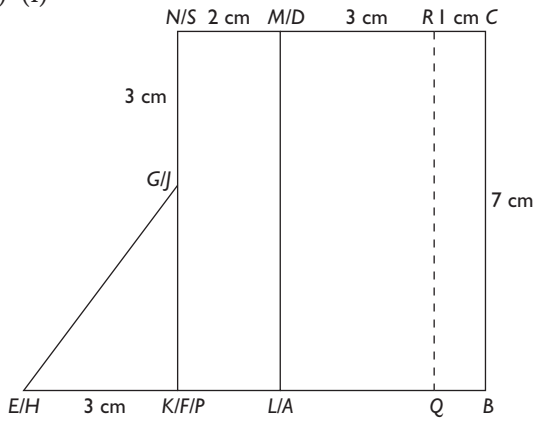

(ii)

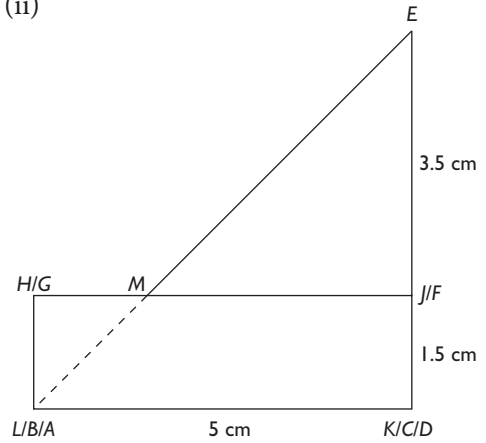

(ii)

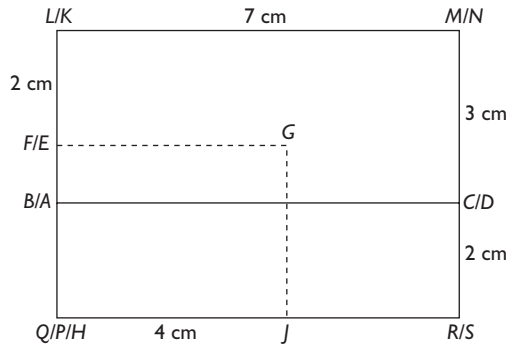

4. (a)

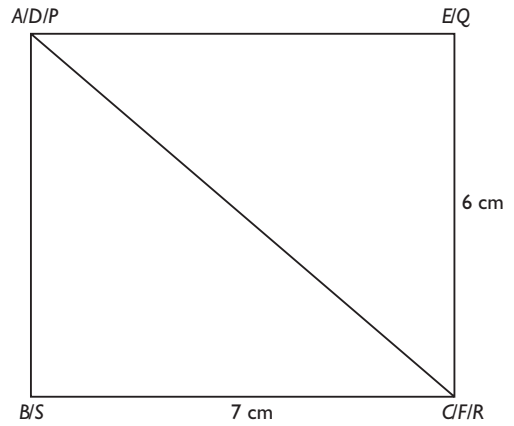

3. (a)

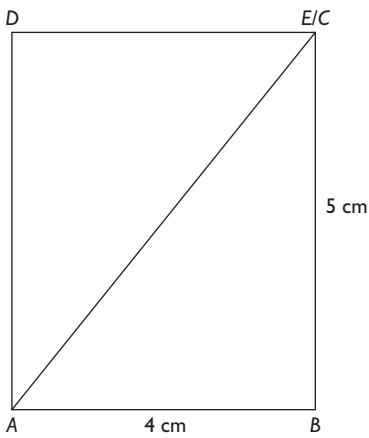

(b) (i)

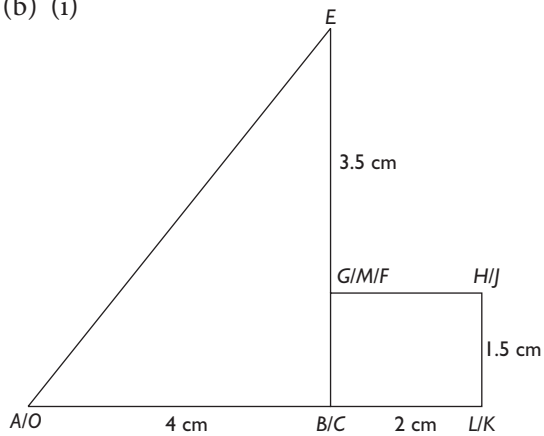

(b) (i)

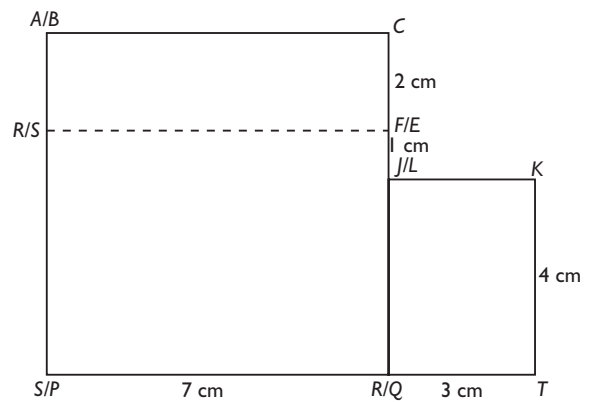

(ii)

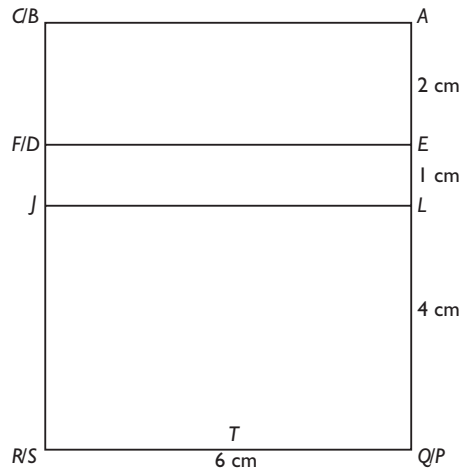

(ii)

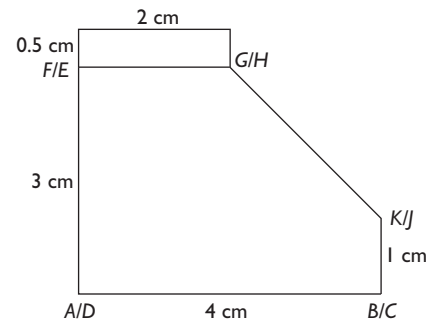

(b) Panjang $GK = \sqrt{2^2 + 2^2}$
 $= \sqrt{8}$
 $= 2.83 \text{ cm}$

5. (a) (i)

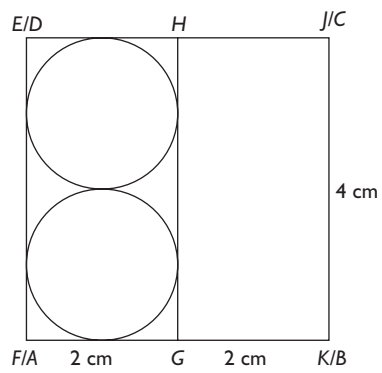

JAWAPAN

KERTAS MODEL SPM

KERTAS 1

1. C

$$\begin{aligned} & (62\,100 + 7\,320) \times 3 \\ &= 69\,420 \times 3 \\ &= 208\,260 \\ &= 2.0826 \times 10^5 \end{aligned}$$

2. B

$$\begin{aligned} & \frac{5.13}{3} + 1.61 \times 4 \\ &= 1.71 + 6.44 \\ &= 8.15 \\ &= 8.2 \text{ (dua angka bererti)} \end{aligned}$$

3. C

$$\begin{aligned} & 5(5^2 + 2 \times 5) \\ &= 5^3 + 2 \times 5^3 \\ &= 1200_5 \end{aligned}$$

4. D

$$\begin{aligned} & \text{Bilangan kertas berwarna} \\ &= 3.5 \text{ kg} \div 7 \times 10^{-3} \text{ g} \\ &= 3\,500 \text{ g} \div 7 \times 10^{-3} \text{ g} \\ &= 500\,000 \\ &= 5 \times 10^5 \end{aligned}$$

5. A

$$\begin{aligned} & \underline{314}_5 \\ & \text{Nilai bagi digit 3} = 3 \times 5^2 \\ & \quad \quad \quad = 3 \times 25 \\ & \quad \quad \quad = 75_{10} \end{aligned}$$

6. C

$$\begin{aligned} & \text{Sudut pedalaman poligon 18 sisi} \\ &= \frac{(18 - 2) \times 180}{18} \end{aligned}$$

$$= 160^\circ$$

Sudut pedalaman oktagon sekata

$$= \frac{(8 - 2) \times 180}{8} = 135^\circ$$

$$m = 160 - 135 = 25$$

7. A

$$\begin{aligned} \angle KML &= \frac{180^\circ - 32^\circ}{2} \\ &= \frac{148^\circ}{2} \\ &= 74^\circ \end{aligned}$$

$$\begin{aligned} \angle KMN &= 180^\circ - 74^\circ \\ &= 106^\circ \end{aligned}$$

$$\begin{aligned} \angle KRQ \text{ (refleks)} &= 360^\circ - 55^\circ \\ &= 305^\circ \end{aligned}$$

Hasil tambah sudut pedalaman

$$\begin{aligned} &= (6 - 2) \times 180^\circ \\ &= 720^\circ \end{aligned}$$

$$\begin{aligned} x + y &= 720 - 305 - 100 - 115 - 106 \\ &= 94 \end{aligned}$$

8. A

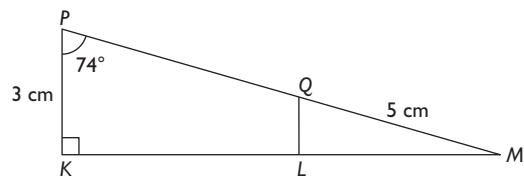

$$\cos 74^\circ = \frac{3}{PM}$$

$$PM = 10.88 \text{ cm}$$

$$\begin{aligned} PQ &= 10.88 - 5 \\ &= 5.88 \text{ cm} \end{aligned}$$

9. B

10. B

$$\begin{aligned} \text{Faktor skala} &= \frac{6}{4} \\ &= \frac{3}{2} \end{aligned}$$

$$\begin{aligned} \text{Panjang } PV &= \frac{3}{2} \times 4 \\ &= 6 \text{ cm} \end{aligned}$$

$$\begin{aligned} \text{Panjang } SV &= 6 \text{ cm} - 4 \text{ cm} \\ &= 2 \text{ cm} \end{aligned}$$

11. A

$$\angle TRS = 180^\circ - 60^\circ = 120^\circ$$

$$\angle QST = \frac{180^\circ - 120^\circ}{2} = 30^\circ$$

$$\begin{aligned} \tan \angle QST &= \tan 30^\circ \\ &= 0.5774 \end{aligned}$$

12. B

$$y = \cos x$$

$$\cos 0 = 1$$

$$\cos 90^\circ = 0 \leftarrow a = 90^\circ$$

$$\cos 180^\circ = -1 \leftarrow b = 180^\circ$$

$$\cos 270^\circ = 0 \leftarrow c = 270^\circ$$

$$\cos 360^\circ = 1 \leftarrow d = 360^\circ$$

$$\begin{aligned} a + b &= 90^\circ + 180^\circ \\ &= 270^\circ \end{aligned}$$

13. B

$$\angle UTV$$

14. B

$$\tan 35^\circ = \frac{3}{PR}$$

$$PR = 4.28$$

Sudut dongakan S dari P

$$= \tan^{-1} \frac{2}{4.28}$$

$$= 25^\circ 1'$$

15. A

$$\tan 50^\circ 12' = 1.2$$

$$\tan 70^\circ 36' = 2.84$$

$$\tan 50^\circ 12' = \frac{BS}{500 + QR}$$

$$500 + QR = \frac{RS}{1.2} \dots \textcircled{1}$$

$$\tan 70^\circ 36' = \frac{RS}{QR}$$

$$QR = \frac{RS}{2.84} \dots \textcircled{2}$$

② ke dalam ①:

$$500 + \frac{RS}{2.84} = \frac{RS}{1.2}$$

$$\frac{RS}{1.2} - \frac{RS}{2.84} = 500$$

$$0.48RS = 500$$

$$RS = 1\ 039$$

$$\approx 1\ 040 \text{ m}$$

16. A

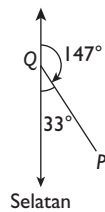

17. D

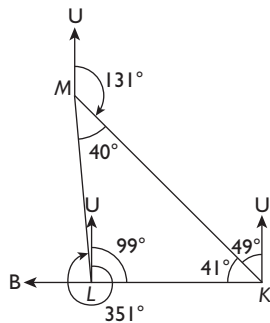

$$180^\circ - 131^\circ = 49^\circ$$

$$90^\circ - 49^\circ = 41^\circ$$

$$180^\circ - 40^\circ - 41^\circ = 99^\circ$$

$$\text{Bearing } M \text{ dari } L = 360^\circ - 9^\circ = 351^\circ$$

18. B

$$50^\circ - 20^\circ = 30^\circ$$

19. C

Jarak XY

$$= (130 - 10) \times 60 \times \cos 60$$

$$= 120 \times 60 \times \cos 60$$

$$= 3\ 600 \text{ batu nautika}$$

20. D

$$16p^4 - 1 = 4^2p^4 - 1$$

$$= (4p^2 + 1)(4p^2 - 1)$$

$$= (4p^2 + 1)(2^2p^2 - 1)$$

$$= (4p^2 + 1)(2p - 1)(2p + 1)$$

21. A

$$\frac{3x - 2}{5} = \frac{x + 1}{2}$$

$$2(3x - 2) = 5(x + 1)$$

$$6x - 4 = 5x + 5$$

$$x = 9$$

22. B

Luas trapezium

$$= \frac{1}{2} \times (x - 3 + x + 1) \times (x + 2)$$

$$= \frac{1}{2} \times (2x - 2) \times (x + 2)$$

$$= (x - 1)(x + 2)$$

$$= x^2 + 2x - x - 2$$

$$= x^2 + x - 2$$

23. C

$$\frac{n}{3} - \frac{1 - 2nr}{r}$$

$$= \frac{n}{3} - \frac{3(1 - 2nr)}{3r}$$

$$= \frac{nr - 3 + 6nr}{3r}$$

$$= \frac{7nr - 3}{3r}$$

24. B

$$\left(\frac{1}{\sqrt{2}}\right)^n = 2^5$$

$$\left(\frac{1}{2^{\frac{1}{2}}}\right)^n = \left(2^{-\frac{1}{2}}\right)^n$$

$$-\frac{1}{2}n = 5$$

$$n = -10$$

25. A

$$\begin{aligned} & \sqrt{\frac{81s^2}{r^4}} \times (3r^{-2}s)^3 \\ &= \frac{9s}{r^2} \times (27r^{-6}s^3) \\ &= \frac{243s^4}{r^8} \end{aligned}$$

26. B

$$\begin{aligned} -\frac{2}{3} &\leq x + 3 \leq 5 - \frac{1}{2}x \\ -\frac{2}{3} &\leq x + 3 & x + 3 &\leq 5 - \frac{1}{2}x \\ -\frac{11}{3} &\leq x & \frac{3}{2}x &\leq 2 \\ & & x &\leq \frac{4}{3} \\ \therefore -\frac{11}{3} &\leq x < \frac{4}{3} \end{aligned}$$

27. B

$$\begin{aligned} \frac{x}{2} - 1 &\leq x & \frac{1}{3}(x + 4) &> x \\ \frac{x}{2} &\geq -1 & x + 4 &> 3x \\ x &\geq -2 & 2x &< 4 \\ & & x &< 2 \\ \therefore x &= -2, -1, 0, 1 \end{aligned}$$

28. C

$$\begin{aligned} \text{Jumlah kekerapan} &= 4 + 6 + 1 + 3 + 5 + 1 \\ &= 20 \\ \text{Median} &= \frac{20}{2} \\ &= 10 \end{aligned}$$

29. A

$$\begin{aligned} y &= x^2 + 4x - 5 \\ 0 &= x^2 + 4x - 5 \\ 0 &= (x - 1)(x + 5) \\ x - 1 &= 0 & x + 5 &= 0 \\ x &= 1 & x &= -5 \end{aligned}$$

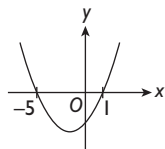

30. D

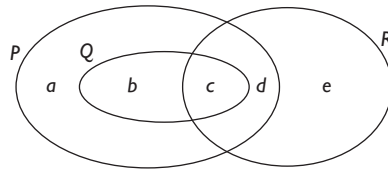

$$\begin{aligned} a = 6, c = ? \\ a + b + c + d + e &= 69 & b + c &= 24 \\ b + c + d + e &= 63 & c + d + e &= 50 \\ b + 50 &= 63 & 13 + c &= 24 \\ b &= 13 & c &= 11 \end{aligned}$$

31. C

32. D

$$\begin{aligned} 12x - 3y &= 15 \\ 3y &= 12x - 15 \\ y &= 4x - 5 \\ 2x + \frac{y}{k} &= 1 \\ \frac{y}{k} &= -2x + 1 \\ y &= -2kx + k \\ 4 &= -2k \\ k &= -2 \end{aligned}$$

33. C

$$\begin{aligned} \text{Koordinat } R &= (-2, 0) \\ \text{Kecerunan } PR &= \frac{3 - 0}{2 - (-2)} \\ &= \frac{3}{4} \end{aligned}$$

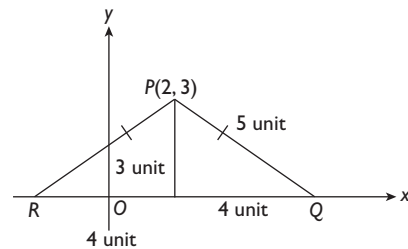

34. B

$$\begin{aligned} \text{Kebarangkalian duit syiling Jepun} &= 1 - \frac{1}{6} - \frac{2}{5} \\ &= \frac{13}{30} \\ \frac{13}{30} \times \text{Jumlah duit syiling} &= 65 \\ \text{Jumlah duit syiling} &= 150 \end{aligned}$$

35. D

Kebarangkalian bukan Pustakawan

$$\begin{aligned} &= \frac{20}{40} + \frac{3}{8} \\ &= \frac{1}{2} + \frac{3}{8} \\ &= \frac{7}{8} \end{aligned}$$

36. C

$$\begin{aligned} w &\propto \frac{x}{y^3} \\ w &= \frac{kx}{y^3} \\ 5 &= \frac{k(80)}{23} \\ k &= \frac{5 \times 8}{80} \\ &= \frac{1}{2} \end{aligned}$$

$$\begin{aligned} w &= \frac{x}{2y^3} \\ 100 &= \frac{25}{2y^3} \\ 2y^3 &= \frac{1}{4} \\ y^3 &= \frac{1}{8} \\ y &= \sqrt[3]{\frac{1}{8}} \\ &= \frac{1}{2} \end{aligned}$$

37. C

$$\begin{aligned} m &\propto z^3 \\ m &= kz^3 \\ 40 &= k(2)^3 \\ k &= 5 \\ m &= 5z^3 \end{aligned}$$

38. B

$$\begin{aligned} T &\propto \frac{N}{H} \\ T &= \frac{kN}{H} \\ 15 &= \frac{k(5)}{1} \\ k &= 3 \\ T &= \frac{3N}{H} \\ T &= \frac{3(28)}{w} \\ w &= \frac{84}{7} \\ &= 12 \end{aligned}$$

39. B

$$\begin{aligned} -3 + 6 &= n \\ n &= 3 \\ 3m + 2n &= 12 \\ 3m + 2(3) &= 12 \\ 3m &= 6 \\ m &= 2 \end{aligned}$$

40. D

$$\begin{aligned} (-5 \times 2) + (y \times 3) &= 11 \\ -10 + 3y &= 11 \\ 3y &= 21 \\ y &= 7 \end{aligned}$$

KERTAS 2

1. (a)

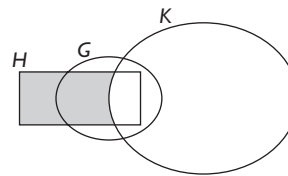

(b)

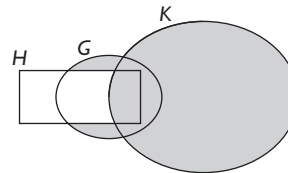

2.

$$\begin{aligned} 3x - 2 &= \frac{(x+1)(x-1)}{3x} \\ 3x(3x-2) &= (x+1)(x-1) \\ 9x^2 - 6x &= x^2 - 1 \\ 8x^2 - 6x + 1 &= 0 \\ (4x-1)(2x-1) &= 0 \\ 4x-1 &= 0 \quad \text{atau} \quad 2x-1 &= 0 \\ 4x &= 1 & 2x &= 1 \\ x &= \frac{1}{4} & x &= \frac{1}{2} \end{aligned}$$

3.

$$\begin{aligned} 2m + 3n &= 9 & \dots \text{ ①} \\ \frac{m}{3} - n &= 2 & \dots \text{ ②} \\ \text{②} \times 6: & 2m - 6n = 12 & \dots \text{ ③} \\ \text{①} - \text{③}: & 3n + 6n = 9 - 12 \\ & 9n = -3 \\ & n = -\frac{1}{3} \end{aligned}$$

Gantikan $n = -\frac{1}{3}$ dalam ①:

$$\begin{aligned} 2m + 3\left(-\frac{1}{3}\right) &= 9 \\ 2m - 1 &= 9 \\ 2m &= 10 \\ m &= 5 \end{aligned}$$

Maka, $m = 5$ dan $n = -\frac{1}{3}$

$$4. \quad ML = \sqrt{9^2 + 12^2}$$

$$= 15 \text{ cm}$$

Isi padu gabungan pepejal

= Isi padu prisma tegak + Isi padu separuh kon

$$= \left[\frac{1}{2} \times 9 \times 12 \times 7 \right] + \left[\frac{1}{2} \times \frac{1}{3} \times \frac{22}{7} \times \left(\frac{7}{2} \right)^2 \times 15 \right]$$

$$= 378 + 96.25$$

$$= 474.25 \text{ cm}^3$$

5. (a) $\angle DCG$ atau $\angle GCD$

$$(b) \quad DG = \sqrt{5^2 - 3^2}$$

$$= 4 \text{ cm}$$

$$CG = \sqrt{3^2 + 10^2}$$

$$= \sqrt{109} \text{ cm}$$

Sudut di antara garis CD dengan tapak $BCFE$:

$$\tan \angle DCG = \frac{4}{\sqrt{109}}$$

$$\angle DCG = \tan^{-1} \frac{4}{\sqrt{109}}$$

$$= 20^\circ 58' \text{ atau } 20.96^\circ$$

6. (a) $x = -3$

(b) Koordinat titik R ialah $(-3, 0)$.
Bagi pintasan- y , $x = 0$.

$$\text{Kecerunan } RS = \frac{5}{4}$$

$$\frac{y - 0}{0 - (-3)} = \frac{5}{4}$$

$$y = \frac{5}{4}(3)$$

$$= \frac{15}{4}$$

$$\text{Maka, pintasan-}y = \frac{15}{4}$$

(c) Kecerunan PQ , $m =$ Kecerunan RS

$$= \frac{5}{4}$$

Gantikan $m = \frac{5}{4}$ dan $(-3, 6)$ dalam $y = mx + c$.

$$6 = \frac{5}{4}(-3) + c$$

$$6 = -\frac{15}{4} + c$$

$$c = \frac{39}{4}$$

Maka, persamaan garis lurus PQ :

$$y = \frac{5}{4}x + \frac{39}{4} \text{ atau } 4y = 5x + 39$$

7. (a) Semua

(b) Implikasi 1:

Jika $p^2 > q^2$, maka $(p + q)(p - q) > 0$.

Implikasi 2:

Jika $(p + q)(p - q) > 0$, maka $p^2 > q^2$.

(c) Kesimpulan:

$$n(n + 2) [(n + 1)^2 + 1], n = 1, 2, 3, 4, \dots$$

8. (a) $(1)(k) - (-2)(3) = 0$

$$k + 6 = 0$$

$$k = -6$$

$$(b) \quad \begin{pmatrix} 3 & -2 \\ 4 & -10 \end{pmatrix} \begin{pmatrix} x \\ y \end{pmatrix} = \begin{pmatrix} -3 \\ 7 \end{pmatrix}$$

$$\begin{pmatrix} x \\ y \end{pmatrix} = \frac{1}{3(-10) - (-2)(4)} \begin{pmatrix} -10 & 2 \\ -4 & 3 \end{pmatrix} \begin{pmatrix} -3 \\ 7 \end{pmatrix}$$

$$= \frac{1}{-22} \begin{pmatrix} -10(-3) + 2(7) \\ -4(-3) + 3(7) \end{pmatrix}$$

$$= \frac{1}{-22} \begin{pmatrix} 44 \\ 33 \end{pmatrix}$$

$$= \begin{pmatrix} -2 \\ -\frac{3}{2} \end{pmatrix}$$

$$\therefore x = -2, y = -\frac{3}{2} \text{ atau } -1\frac{1}{2}$$

9. (a) Perimeter seluruh rajah

$$= \left(2 \times \frac{22}{7} \times 14 \right) + \left(\frac{1}{2} \times 2 \times \frac{22}{7} \times 11 \right) +$$

$$\left(2 \times \frac{22}{7} \times 7 \right) + 4 + 4 + 14$$

$$= 88 + 34\frac{4}{7} + 44 + 22$$

$$= 188\frac{4}{7} \text{ cm atau } 188.57 \text{ cm}$$

(b) Luas kawasan berlerek

$$= \left(\frac{1}{2} \times \frac{22}{7} \times 14^2 \right) + \left[\left(\frac{1}{2} \times \frac{22}{7} \times 14^2 \right) - \right.$$

$$\left. \left(\frac{1}{2} \times \frac{22}{7} \times 11^2 \right) \right]$$

$$= 308 + \left(308 - 190\frac{1}{2} \right)$$

$$= 308 + 117\frac{6}{7}$$

$$= 425\frac{6}{7} \text{ cm}^2 \text{ atau } 425.86 \text{ cm}^2$$

10. (a)

		Kesudahan bola yang dipilih		
		M	B	K
Kesudahan putaran cakera	2	(2, M)	(2, B)	(2, K)
	4	(4, M)	(4, B)	(4, K)
	5	(5, M)	(5, B)	(5, K)
	6	(6, M)	(6, B)	(6, K)
	7	(7, M)	(7, B)	(7, K)
	8	(8, M)	(8, B)	(8, K)

(b) (i) $\{(6, M), (6, B), (6, K)\}$

$$\begin{aligned} \text{Kebarangkalian} &= \frac{3}{18} \\ &= \frac{1}{6} \end{aligned}$$

(ii) $\{(5, M), (5, B), (5, K), (7, M), (7, B), (7, K), (2, M), (4, M), (6, M), (8, M)\}$

$$\begin{aligned} \text{Kebarangkalian} &= \frac{10}{18} \\ &= \frac{5}{9} \end{aligned}$$

11. (a) $11 - 6 = 5 \text{ s}$

$$\begin{aligned} \text{(b)} \quad \frac{16 - v}{6} &= \frac{5}{2} \\ 16 - v &= 15 \\ v &= 1 \end{aligned}$$

$$\begin{aligned} \text{(c) Jumlah jarak} &= \left[\frac{1}{2} \times (16 + 1) \times 6 \right] + (5 \times 16) + \left[\frac{1}{2} \times (16 + 30) \times 3 \right] \\ &= 51 + 80 + 69 \\ &= 200 \text{ m} \end{aligned}$$

12. (a) (i) $(8, 4) \xrightarrow{\mathbf{T}} (10, 1) \xrightarrow{\mathbf{T}} (12, -2)$

(ii) $(8, 4) \xrightarrow{\mathbf{T}} (10, 1) \xrightarrow{\mathbf{S}} (10, -3)$

(b) (i) \mathbf{W} = Putaran 90° lawan arah jam pada pusat $(-2, -1)$

(ii) \mathbf{V} = Pembesaran dengan faktor skala 3 pada pusat $E(-1, 4)$

$$\begin{aligned} \text{(c) Luas } EKLM &= 3^2 \times \text{Luas } ABCD \\ &= 9 \times 30 \\ &= 270 \text{ cm}^2 \end{aligned}$$

$$\begin{aligned} \text{Luas kawasan berlorek} &= 270 - 30 \\ &= 240 \text{ cm}^2 \end{aligned}$$

13. (a) $y = -x^3 + 2x + 5$

x	-3	-2	-1	0	1	2	3	3.5	4
y	26	9	4	5	6	1	-16	-30.9	-51

(b)

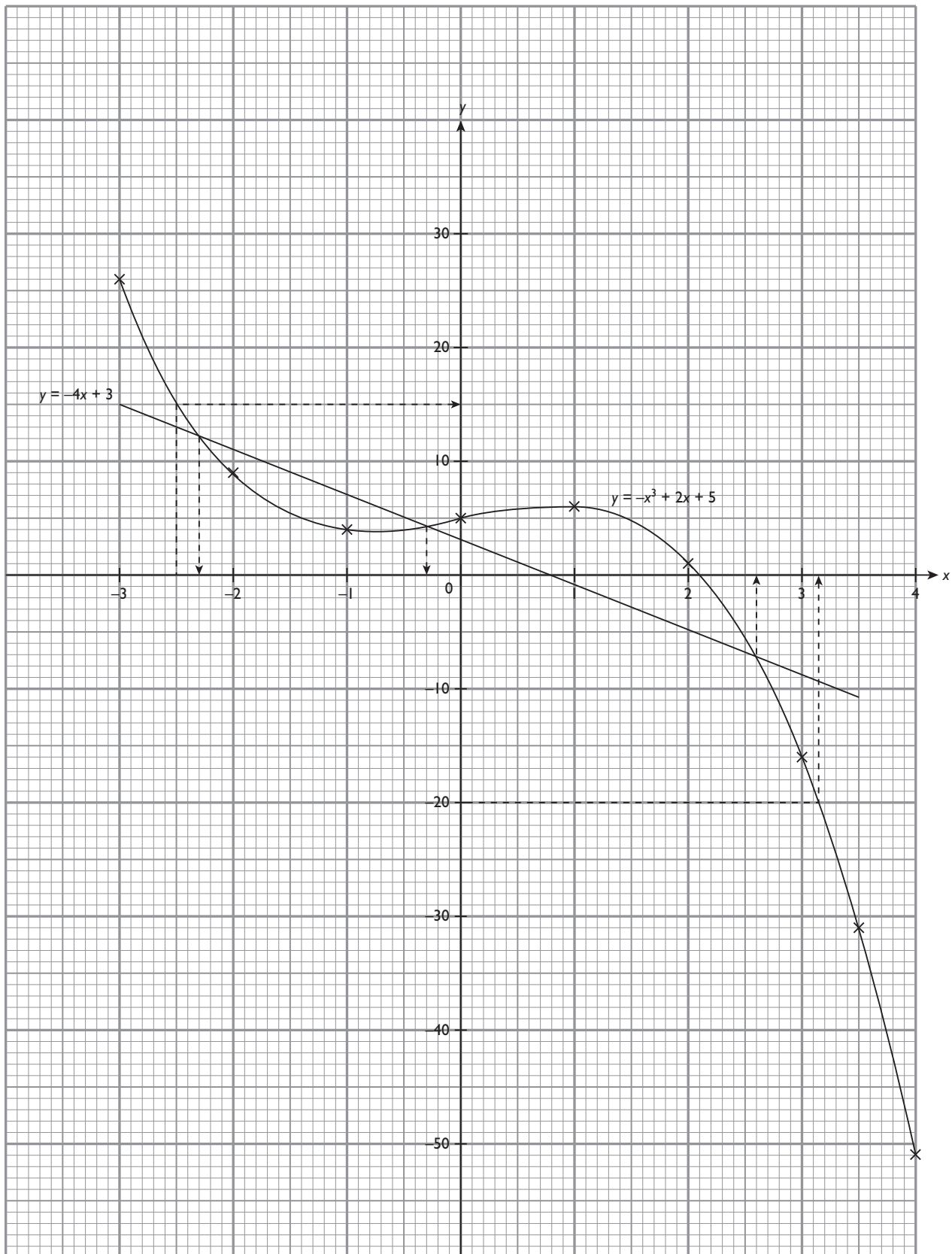

- (c) (i) 15
(ii) 3.15

(d) $y = -x^3 + 2x + 5$ ①
 $0 = -x^3 + 6x + 2$ ②
 ① - ②: $y = -4x + 3$
 Persamaan garis lurus: $y = -4x + 3$
 $x = -2.3, -0.3, 2.6$

14. (a) Min

$$= \frac{(5 \times 62) + (11 \times 67) + (24 \times 72) + (38 \times 77) + (40 \times 82) + (52 \times 87) + (20 \times 92) + (10 \times 97)}{200}$$

$$= \frac{16\,315}{200}$$

$$= 81.58 \text{ kg}$$

(b)

Sempadan atas	Kekerapan longgokan
59.5	0
64.5	5
69.5	16
74.5	40
79.5	78
84.5	118
89.5	170
94.5	190
99.5	200

(c) Rujuk graf di halaman 9.

- (d) (i) Julat antara kuartil
 = kuartil ketiga - kuartil pertama
 = $87.5 - 76$
 = 11.5
 (ii) Bilangan pekerja yang mempunyai berat berlebihan
 = $200 - 134$
 = 66

Kekerapan longgokan

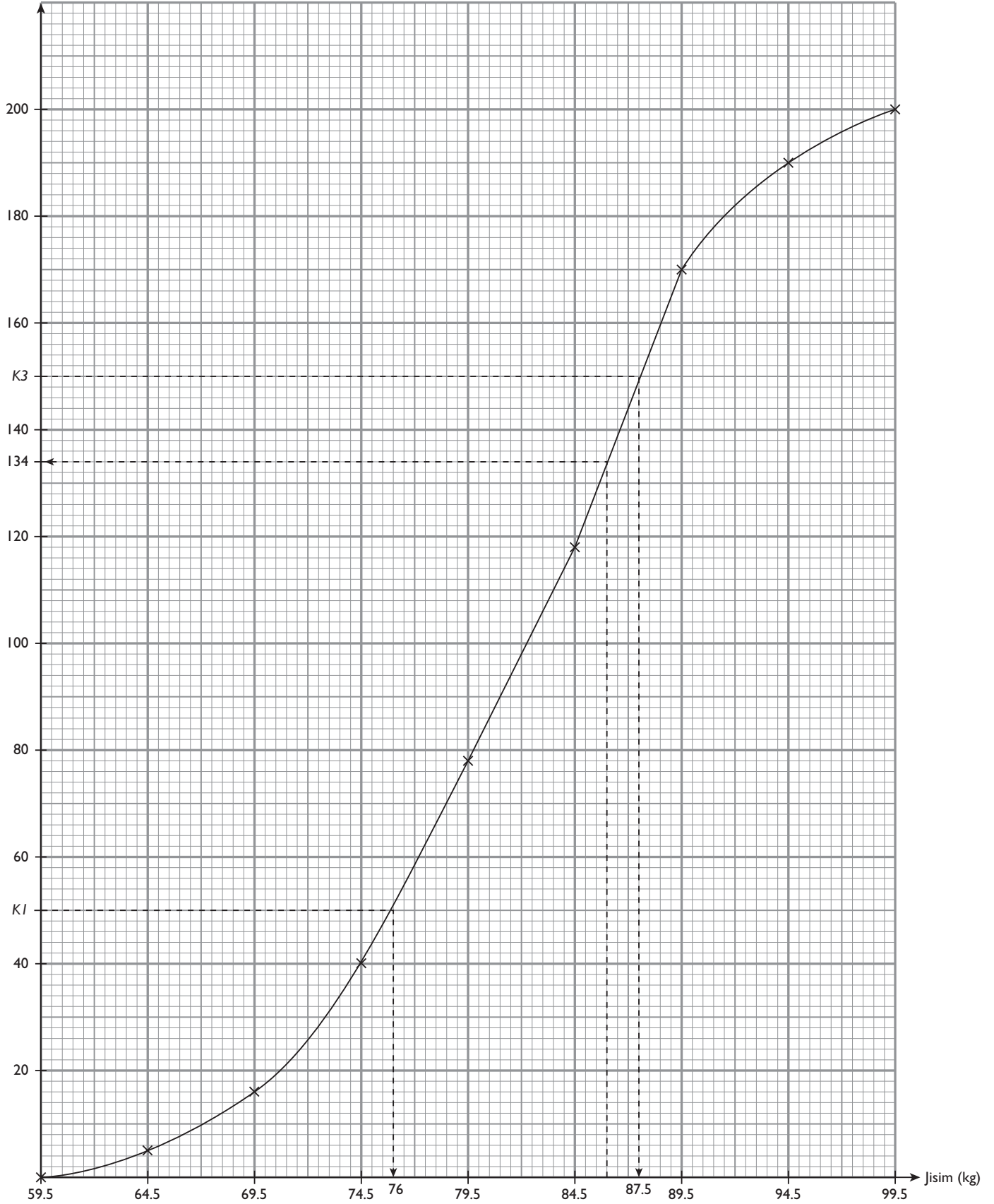

15. (a)

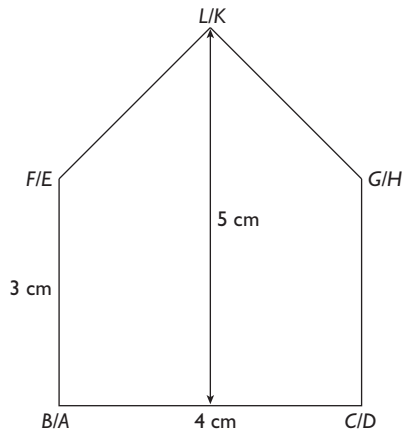

(b) (i)

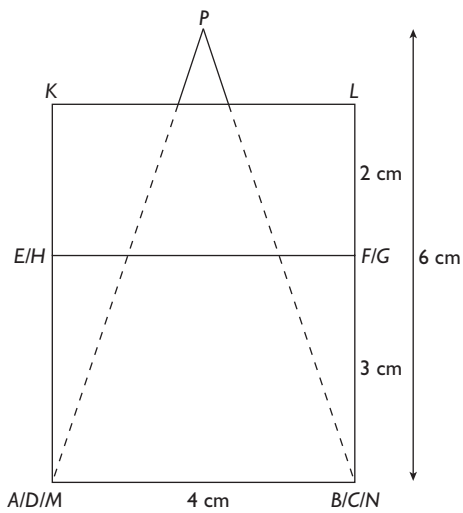

(ii)

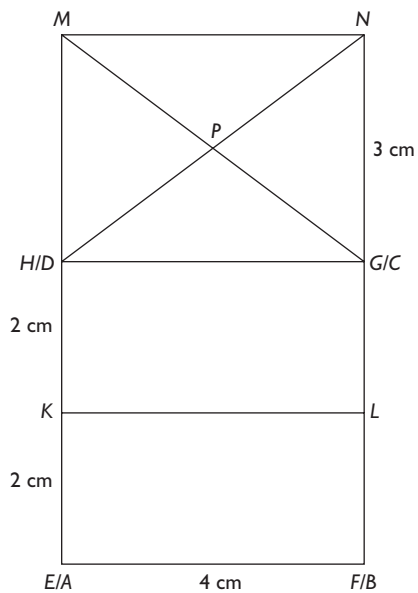

16. (a) Longitud $R = 180^\circ - 35^\circ$
 $= 145^\circ T$
 \therefore Kedudukan $R = (40^\circ U, 145^\circ T)$

(b) Jarak terdekat $QR = 100 \times 60$
 $= 6\,000$ batu nautika

(c) (i) Latitud $K = \frac{5\,760}{60} - 40$
 $= 96 - 40$
 $= 56^\circ S$

(ii) Masa yang diambil $= \frac{5\,760}{800}$
 $= 7.2$ jam
 $= 7$ jam 12 minit

Waktu tiba di K:

0 9	0 0	
+	7 1 2	
1 6	1 2	→ Jam 1612

JAWAPAN

PRAKTIS AWAL SPM

KERTAS 1

1. C

$$\begin{aligned}\angle PKL &= \frac{(5-2) \times 180^\circ}{5} \\ &= 108^\circ\end{aligned}$$

$$\begin{aligned}\angle PKR &= 180^\circ - 108^\circ \\ &= 72^\circ\end{aligned}$$

$$\begin{aligned}\angle QPK &= 360^\circ - 105^\circ - 108^\circ \\ &= 147^\circ\end{aligned}$$

$$\begin{aligned}x &= 360 - 55 - 72 - 147 \\ &= 86\end{aligned}$$

2. D

$$\begin{aligned}y + x &= 360^\circ - 90^\circ \\ &= 210^\circ\end{aligned}$$

$$y < x$$

Bilangan sisi = 10

$$x = \frac{(10-2) \times 180^\circ}{10}$$

$$= 144^\circ$$

$$y = 270^\circ - 144^\circ$$

$$= 126^\circ$$

$$126^\circ < 144^\circ$$

∴ Maka, bilangan sisi bagi poligon itu ialah 10.

3. B

$$\begin{aligned}\angle TUV \text{ (refleks)} &= 360^\circ - 124^\circ \\ &= 236^\circ\end{aligned}$$

$$\begin{aligned}\angle PQR \text{ (refleks)} &= 360^\circ - 162^\circ \\ &= 198^\circ\end{aligned}$$

Hasil tambah sudut pedalaman poligon PQRUT

$$= (5-2) \times 180^\circ$$

$$= 3 \times 180^\circ$$

$$= 540^\circ$$

$$x + y = 540 - 236 - 38 - 198$$

$$= 68$$

4. C

$$\begin{aligned}\angle RSU &= 180^\circ - 54^\circ \\ &= 126^\circ\end{aligned}$$

$$\angle SUT = \frac{180^\circ - 54^\circ}{2}$$

$$= 63^\circ$$

$$\angle SUV = 180^\circ - 63^\circ$$

$$= 117^\circ$$

Hasil tambah sudut pedalaman heksagon

$$= (6-2) \times 180^\circ$$

$$= 720^\circ$$

$$2x = 720 - 123^\circ - 140^\circ - 117^\circ - 126^\circ$$

$$= 214$$

$$x = 107$$

5. C

Sudut pedalaman pentagon sekata

$$= \frac{(5-2) \times 180^\circ}{5}$$

$$= 108^\circ$$

$$x = 108 - 18$$

$$= 90$$

$$y = 180 - 56$$

$$= 124$$

$$x + y = 90 + 124$$

$$= 214$$

6. C

$$\text{Faktor skala} = \frac{ST}{SU}$$

$$= \frac{2}{6}$$

$$= \frac{1}{3}$$

7. A

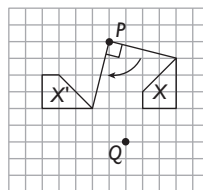

8. A

$$\begin{aligned}(p+q)^2 - (p+q)(p-q) &= (p+q)(p+q) - (p+q)(p-q) \\ &= p^2 + pq + pq + q^2 - (p^2 - pq + pq - q^2) \\ &= 2pq + 2q^2\end{aligned}$$

9. C

$$\begin{aligned}4x(x-y) - (2x+y)^2 &= 4x(x-y) - (2x+y)(2x+y) \\ &= 4x^2 - 4xy - (4x^2 + 2xy + 2xy + y^2) \\ &= -8xy - y^2\end{aligned}$$

10. D

$$\begin{aligned}(3p+2)(q-1) + (p-2)(q-2) &= 3pq - 3p + 2q - 2 + (pq - 2p - 2q + 4) \\ &= 4pq - 5p + 2\end{aligned}$$

11. D

$$\begin{aligned}\frac{1}{m-n} - \frac{3m}{m^2-n^2} &= \frac{1(m+n)}{(m-n)(m+n)} - \frac{3m}{m^2-n^2} \\ &= \frac{m+n-3m}{m^2-n^2} \\ &= \frac{-2m+n}{m^2-n^2}\end{aligned}$$

12. B

$$\begin{aligned} & \frac{4pq + 8q}{16 - q^2} \div \frac{8pq}{4 - q} \\ &= \frac{4pq + 8q}{(4 - q)(4 + q)} \times \frac{4 - q}{8pq} \\ &= \frac{4q(p + 2)}{8pq(4 + q)} \\ &= \frac{p + 2}{2p(4 + q)} \end{aligned}$$

13. D

$$\begin{aligned} & \frac{5 \times 2}{6r \times 2} - \frac{10r - 2}{12r} \\ &= \frac{10 - 10r + 2}{12r} \\ &= \frac{12 - 10r}{12r} \\ &= \frac{1}{2} \frac{(6 - 5r)}{6r} \\ &= \frac{6 - 5r}{6r} \end{aligned}$$

14. B

$$\begin{aligned} & \frac{2t^2 + q}{3} = 3(2 + 5q) \\ & 2t^2 + q = 9(2 + 5q) \\ & 2t^2 + q = 18 + 45q \\ & 44q = 2t^2 - 18 \\ & q = \frac{1}{44} (2t^2 - 18) \\ &= \frac{t^2 - 9}{22} \end{aligned}$$

15. D

$$\begin{aligned} & p = \frac{q^3}{4} + 5 \\ & \frac{q^3}{4} = p - 5 \\ & q^3 = 4p - 20 \\ & q = \sqrt[3]{4p - 20} \end{aligned}$$

16. A

$$\begin{aligned} & y = \frac{1}{2} + \frac{x}{5} \\ & \frac{x}{5} = y - \frac{1}{2} \\ & x = 5y - \frac{5}{2} \\ &= \frac{10y - 5}{2} \end{aligned}$$

17. B

$$\begin{aligned} & \frac{4x}{3} + 7 = 9 \\ & \frac{4x}{3} = 2 \\ & 4x = 6 \\ & x = \frac{6}{4} \\ &= \frac{3}{2} \end{aligned}$$

18. A

$$\begin{aligned} & 15 - \frac{4y}{5} = 7 \\ & \frac{4y}{5} = 8 \\ & 4y = 40 \\ & y = 10 \end{aligned}$$

19. A

$$\begin{aligned} & 6 - \frac{2x}{3} = 2(x - 4) \\ & 6 - \frac{2x}{3} = 2x - 8 \\ & 2x + \frac{2x}{3} = 6 + 8 \\ & \frac{8x}{3} = 14 \\ & 8x = 42 \\ & x = \frac{21}{4} \end{aligned}$$

20. A

$$\begin{aligned} & p^2 = \left(2^{-3} \times 256^{\frac{3}{4}} \right)^2 \\ &= 2^{-6} \times 256^{\frac{3}{2}} \\ &= \frac{1}{2^6} \times (\sqrt{256})^3 \\ &= \frac{1}{64} \times 16^3 \\ &= \frac{4096}{64} \\ &= 64 \end{aligned}$$

21. C

$$\begin{aligned} & \left(\frac{p^{12} \times (9q^6)^{\frac{1}{2}}}{(p^{15}q^{25})^{\frac{1}{5}}} \right)^3 \\ &= \left(\frac{p^{12} \times 3q^3}{p^3q^5} \right)^3 \\ &= \frac{p^{36} \times 27q^9}{p^9q^{15}} \\ &= 27q^{27}q^{-6} \\ &= \frac{27p^{27}}{q^6} \end{aligned}$$

22. D

$$\begin{aligned} & (3^{10} \times 243)^{\frac{1}{5}} \div (p^{\frac{1}{4}})^4 \\ &= \frac{3^2 \times \sqrt[5]{243}}{p} \\ &= \frac{9 \times 3}{p} \\ &= \frac{27}{p} \end{aligned}$$

23. A

$$\begin{aligned} & \frac{f^4 g^3 \times (81 f^4 g^{12})^{\frac{1}{4}}}{f} \\ &= \frac{f^4 g^3 \times 3 f g^3}{f} \\ &= \frac{3 f^5 g^6}{f} \\ &= 3 f^4 g^6 \end{aligned}$$

24. A

$$\begin{aligned} 6m - 5 &\leq 17 + 8m \\ -5 - 17 &\leq 8m - 6m \\ 2m &\geq -22 \\ m &\geq -11 \end{aligned}$$

25. D

$$\begin{aligned} \frac{y}{3} - 9 &\geq -11 \\ \frac{y}{3} &\geq -2 \\ y &\geq -6 \\ 1 - 4y &> 7 \\ 4y &< -6 \\ y &< -\frac{3}{2} \\ \therefore y &= -6, -5, -4, -3, -2 \end{aligned}$$

26. B

$$\begin{aligned} 7 - y &\geq 4 \\ y &\leq 3 \\ \frac{4y}{3} &\geq -3 \\ 4y &\geq -9 \\ y &\geq -\frac{9}{4} \\ \therefore y &= -2, -1, 0, 1, 2, 3 \end{aligned}$$

27. A

$$\begin{aligned} 6 - 3y &\geq 8 + 4y \\ 7y &\leq -2 \\ y &\leq -\frac{2}{7} \end{aligned}$$

28. D

Bilangan kek yang dijual pada bulan Julai dan Ogos

$$\begin{aligned} &= 560 - 5(40) \\ &= 560 - 200 \\ &= 360 \end{aligned}$$

Bilangan kek yang dijual pada bulan Ogos

$$\begin{aligned} &= 360 \div 3 \times 2 \\ &= 240 \end{aligned}$$

29. C

$$\begin{aligned} 120^\circ + 80^\circ + 3x^\circ + 2x^\circ + 30^\circ &= 360^\circ \\ 5x^\circ &= 130 \\ x &= 26 \end{aligned}$$

$$\begin{aligned} \text{Sudut gred D} &= 2 \times 26^\circ \\ &= 52^\circ \end{aligned}$$

Bilangan murid yang memperoleh gred D

$$\begin{aligned} &= \frac{52}{360} \times 1440 \\ &= 208 \end{aligned}$$

30. B

$$\begin{aligned} & 7 \times 10 + 15 \times 20 + 6 \times 30 + 5 \times 40 \\ \text{Min} &= \frac{\quad + 3 \times 50}{36} \\ &= \frac{900}{36} \\ &= 25 \end{aligned}$$

KERTAS 2

1. $4x - y = -11$ ①
 $x + 3y = 7$ ②

$$\begin{aligned} \text{①} \times 3: & \quad 12x - 3y = -33 \quad \text{..... ③} \\ \text{②} + \text{③}: & \quad 13x = -26 \\ & \quad x = -2 \end{aligned}$$

Gantikan $x = -2$ dalam ②.

$$\begin{aligned} -2 + 3y &= 7 \\ 3y &= 9 \\ y &= 3 \end{aligned}$$

$$\therefore x = -2, y = 3$$

2. Katakan harga bagi 1 kg langsung ialah RMx.
Harga bagi 1 kg rambutan ialah RMy.

$$\begin{aligned} x + y &= 12 \quad \text{..... ①} \\ 5x - y &= 30 \quad \text{..... ②} \end{aligned}$$

$$\begin{aligned} \text{①} + \text{②}: & \quad 6x = 42 \\ & \quad x = 7 \end{aligned}$$

Gantikan $x = 7$ dalam ①.

$$\begin{aligned} 7 + y &= 12 \\ y &= 5 \end{aligned}$$

Harga bagi 1 kg rambutan ialah RM5.

$$\begin{aligned}
3. \quad & 5x + y = 15 \quad \dots\dots \textcircled{1} \\
& -x + 4y = -24 \quad \dots\dots \textcircled{2} \\
\textcircled{1} \times 4: & 20x + 4y = 60 \quad \dots\dots \textcircled{3} \\
\textcircled{2} - \textcircled{3}: & -21x = -84 \\
& x = 4
\end{aligned}$$

Gantikan $x = 4$ dalam $\textcircled{1}$.

$$\begin{aligned}
5(4) + y &= 15 \\
20 + y &= 15 \\
y &= -5 \\
\therefore x &= 4, y = -5
\end{aligned}$$

4. Katakan bilangan basikal ialah x dan bilangan basikal roda tiga ialah y .

$$\begin{aligned}
2x + 2y &= 56 \quad \dots\dots \textcircled{1} \\
2x + 3y &= 72 \quad \dots\dots \textcircled{2} \\
\textcircled{2} - \textcircled{1}: & y = 16 \quad \dots\dots \textcircled{3}
\end{aligned}$$

Gantikan $y = 16$ dalam $\textcircled{1}$.

$$\begin{aligned}
2x + 32 &= 56 \\
2x &= 24 \\
x &= 12 \\
\therefore x &= 12, y = 16
\end{aligned}$$

Bilangan basikal ialah 12 buah.

Bilangan basikal roda tiga ialah 16 buah.

5. (a) Katakan x ialah bilangan pusingan lengkap

$$x \times 2 \times \frac{22}{7} \times 10 = 800$$

$$\begin{aligned}
x &= \frac{800 \times 7}{2 \times 22 \times 10} \\
&= 12.73
\end{aligned}$$

Minimum bilangan pusingan lengkap = 13

(b) Katakan x ialah bahagian kek bersaiz besar yang bersamaan dengan dua kek bersaiz kecil.

$$\begin{aligned}
x \times \frac{22}{7} \times \left(\frac{35}{2}\right)^2 &= 2 \times \frac{22}{7} \times \left(\frac{21}{2}\right)^2 \\
x &= \frac{2 \times \frac{22}{7} \times \left(\frac{21}{2}\right)^2}{\frac{22}{7} \times \left(\frac{35}{2}\right)^2} \\
&= \frac{18}{25}
\end{aligned}$$

$$\begin{aligned}
6. (a) \text{ Luas kawasan berlorek} &= \text{Luas } OPQR - \text{Luas } OAB \\
&= \left(\frac{3}{4} \times \frac{22}{7} \times 10^2\right) - \left(\frac{1}{4} \times \frac{22}{7} \times 8^2\right) \\
&= 235.71 - 50.29 \\
&= 185.42 \text{ cm}^2
\end{aligned}$$

$$\begin{aligned}
(b) \text{ Perimeter kawasan berlorek} &= PQR + RO + OA + AB + BO + OP \\
&= \left(\frac{270}{360} \times 2 \times \frac{22}{7} \times 10\right) + 10 + 8 + \\
&\quad \left(\frac{90}{360} \times 2 \times \frac{22}{7} \times 8\right) + 8 + 10 \\
&= 47.14 + 18 + 12.57 + 18 \\
&= 95.71 \text{ cm}
\end{aligned}$$

7. Isi padu gabungan pepejal

$$\begin{aligned}
&= \frac{1}{2}(7)(8 + 10)(12) + \left(\frac{1}{2} \times \frac{22}{7} \times 3.5^2 \times 5\right) \\
&= 756 + 96.25 \\
&= 852.25 \text{ cm}^3
\end{aligned}$$

8. Isi padu yang tinggal

$$\begin{aligned}
&= \text{Isi padu kubus} - \text{Isi padu kon} \\
&= (12 \times 12 \times 12) - \left(\frac{1}{3} \times \frac{22}{7} \times 4.5^2 \times 12\right) \\
&= 1728 - 254.57 \\
&= 1473.43 \text{ cm}^3
\end{aligned}$$

9. Isi padu gabungan pepejal

$$\begin{aligned}
&= \text{Isi padu hemisfera} + \text{Isi padu silinder} \\
&= \left(\frac{2}{3} \times \frac{22}{7} \times 7^3\right) + \left(\frac{22}{7} \times 7^2 \times 14\right) \\
&= 718.67 + 2156 \\
&= 2874.67 \text{ cm}^3
\end{aligned}$$